

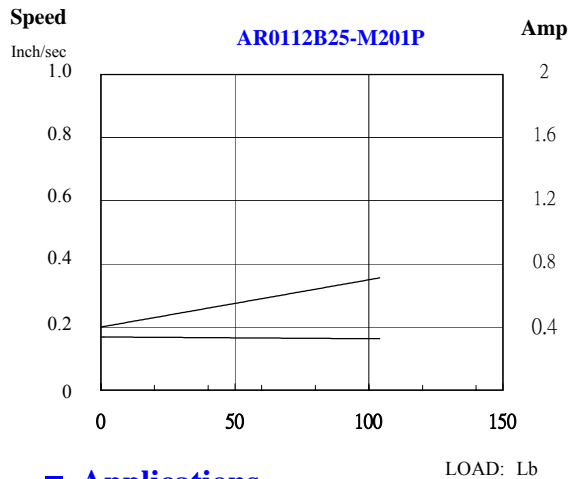

Performance Curve

Voltage : 24.0 Vdc



Features

- Clevis mounting
- Rugged high grade aluminum die-casting housing
- Very quiet operation
- Load capacity 300 lbs
- ACME lead screw with limit switch

Options

- Special brackets
- Special adaptors
- Custom designed mounting
- Custom designed stroke length
- Motor voltage : 12~ 220Vdc
- Over current protection
- Customized performance

Applications

- Lift chair
- Power Chair

Dimensions Inch[mm]

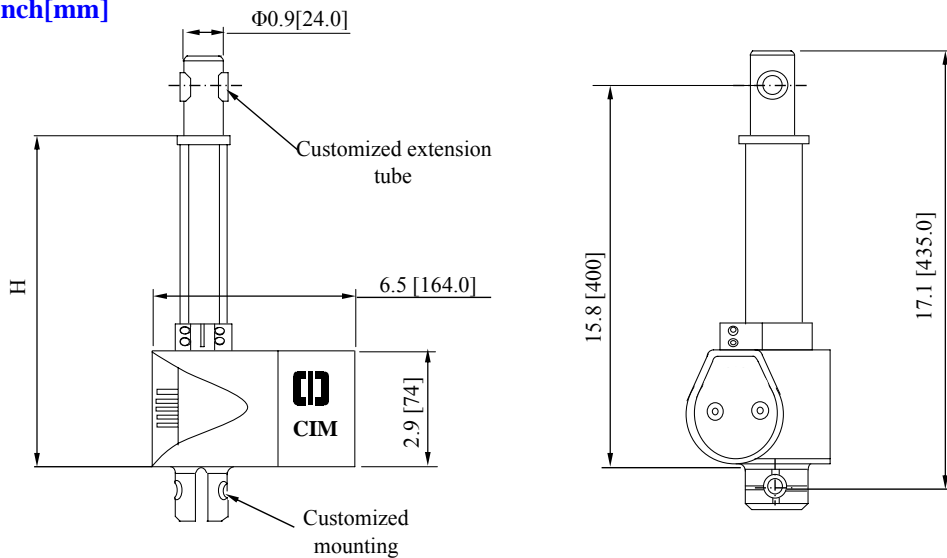

Selected Performance Data

Model	Application	Voltage	No Load		Normal Operating Load			Max. Operating Load			Stroke Length		Height (H)		Motor Dia.	
			Speed	Current	Load	Speed	Current	Load	Speed	Current	Inch	mm	Inch	mm	Inch	mm
			Vdc	Inch/sec	A	Lb	Inch/sec	A	Lb	Inch/sec	A					
AR0112B25-M201P	Lift chair	24.0	0.17	0.4	200	0.157	1.00	300.0	0.156	1.2	5.0	127.0	13.35	339.0	2.5	63.5

Email: cimsales@cclmotors.com

North America: 30 Technology Drive, Warren, New Jersey 07059 USA

Hong Kong: 4/F, No. 6, On Lok Mun St., On Lok Tsuen, Fanling, Hong Kong

Website: www.cimmotor.com

Tel: (908) 753 7100 Fax: (908) 753 9100

Tel: (852) 3125 0000 Fax: (852) 3125 0122

This product brochure is subject to copyright owned by the CCL Industrial Motors Limited. Any reproduction, adaptation, distribution, dissemination or making available of such copyright works to the public is strictly prohibited. All product information is for reference only, details specification is subject to final confirmation.