



KK1000A/2000V

HIGH POWER THYRISTOR FOR INVERTER AND CHOPPER APPLICATIONS

Features:

- . All Diffused Structure
- . Interdigitated Amplifying Gate Configuration
- . Guaranteed Maximum Turn-Off Time
- . High dV/dt Capability
- . Pressure Assembled Device

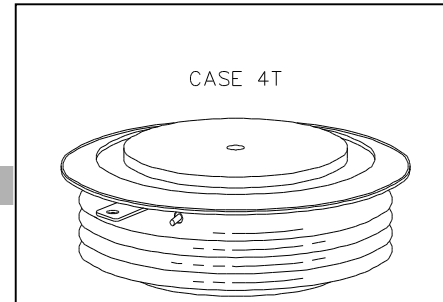

ELECTRICAL CHARACTERISTICS AND RATINGS

Blocking - Off State

Device Type	V _{RRM} (1)	V _{DRM} (1)	V _{RSM} (1)
KK1000A	2000	2000	2100

V_{RRM} = Repetitive peak reverse voltage

V_{DRM} = Repetitive peak off state voltage

V_{RSM} = Non repetitive peak reverse voltage (2)

Repetitive peak reverse leakage and off state leakage	I _{RRM} / I _{DRM}	10 mA 65 mA (3)
Critical rate of voltage rise	dV/dt (4)	600V/μsec

Notes:

All ratings are specified for T_j=25 °C unless otherwise stated.

(1) All voltage ratings are specified for an applied 50Hz/60Hz sinusoidal waveform over the temperature range -40 to +125 °C.

(2) 10 msec. max. pulse width

(3) Maximum value for T_j = 125 °C.

(4) Minimum value for linear and exponential waveshape to 80% rated V_{DRM}. Gate open. T_j = 125 °C.

(5) Non-repetitive value.

Conducting - on state

Parameter	Symbol	Min.	Max.	Typ.	Units	Conditions
Average value of on-state current	I _{T(AV)}		1000		A	T _c =85°C
RMS value of on-state current	I _{TRMS}		1570		A	Nominal value
Peak one cPSTCle surge (non repetitive) current	I _{TSM}		18400		A	8.3 msec (60Hz), sinusoidal wave-shape, 180° conduction, T _j = 125 °C
			16900		A	10.0 msec (50Hz), sinusoidal wave-shape, 180° conduction, T _j = 125 °C
I square t	I ² t		1.66x10 ⁶		A ² s	8.3 msec and 10.0 msec
Latching current	I _L		1000		mA	V _D = 24 V; R _L = 12 ohms
Holding current	I _H		500		mA	V _D = 24 V; I = 2.5 A
Peak on-state voltage	V _{TM}		2.25		V	I _{TM} = 2000 A; Duty cPSTCle ≤ 0.01%
Critical rate of rise of on-state current (5, 6)	di/dt		1000		A/μs	Switching from V _{DRM} ≤ 1000 V, non-repetitive

KK1000A/2000V

Gating

Parameter	Symbol	Min.	Max.	Typ.	Units	Conditions
Peak gate power dissipation	P_{GM}		200		W	$t_p = 40 \mu s$
Average gate power dissipation	$P_{G(AV)}$		5		W	
Peak gate current	I_{GM}		10		A	
Gate current required to trigger all units	I_{GT}		300 150 125		mA mA mA	$V_D = 6 V; R_L = 3 \text{ ohms}; T_j = -40 \text{ }^\circ\text{C}$ $V_D = 6 V; R_L = 3 \text{ ohms}; T_j = +25 \text{ }^\circ\text{C}$ $V_D = 6 V; R_L = 3 \text{ ohms}; T_j = +125 \text{ }^\circ\text{C}$
Gate voltage required to trigger all units	V_{GT}	0.30	5 3		V V V	$V_D = 6 V; R_L = 3 \text{ ohms}; T_j = -40 \text{ }^\circ\text{C}$ $V_D = 6 V; R_L = 3 \text{ ohms}; T_j = 0-125 \text{ }^\circ\text{C}$ $V_D = \text{Rated } V_{DRM}; R_L = 1000 \text{ ohms}; T_j = +125 \text{ }^\circ\text{C}$
Peak negative voltage	V_{GRM}		5		V	

Dynamic

Parameter	Symbol	Min.	Max.	Typ.	Units	Conditions
Delay time	t_d		1.5	0.7	μs	$I_{TM} = 500 \text{ A}; V_D = \text{Rated } V_{DRM}$ Gate pulse: $V_G = 20 \text{ V}; R_G = 20 \text{ ohms}; t_r = 0.1 \mu s; t_p = 20 \mu s$
Turn-off time (with $V_R = -50 \text{ V}$)	t_q		50		μs	$I_{TM} = 1000 \text{ A}; di/dt = 25 \text{ A}/\mu s;$ $V_R \geq -50 \text{ V};$ Re-applied $dV/dt = 200 \text{ V}/\mu s$ linear to 80% $V_{DRM}; V_G = 0;$ $T_j = 125 \text{ }^\circ\text{C};$ Duty cPSTCle $\geq 0.01\%$
Reverse recovery charge	Q_{rr}		*	2000	μC	$I_{TM} = 1000 \text{ A}; di/dt = 25 \text{ A}/\mu s;$ $V_R \geq -50 \text{ V}$

* For guaranteed max. value, contact factory.

THERMAL AND MECHANICAL CHARACTERISTICS AND RATINGS

Parameter	Symbol	Min.	Max.	Typ.	Units	Conditions
Operating temperature	T_j	-40	+125		$^\circ\text{C}$	
Storage temperature	T_{stg}	-40	+150		$^\circ\text{C}$	
Thermal resistance - junction to case	$R_{\Theta(j-c)}$		0.023 0.046		$^\circ\text{C}/\text{W}$	Double sided cooled Single sided cooled
Thermal resistance - case to sink	$R_{\Theta(j-c)}$		0.010 0.020		$^\circ\text{C}/\text{W}$	Double sided cooled * Single sided cooled *
Mounting force	P	19.5	21		kN	

* Mounting surfaces smooth, flat and greased

Note : for case outline and dimensions, see case outline drawing in page 3 of this Technical Data

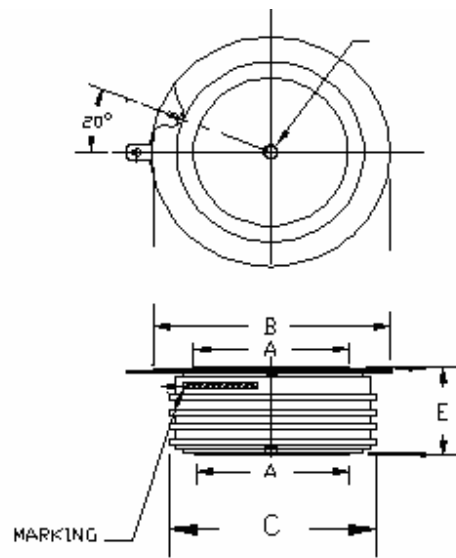

A: 47 mm

B: 74 mm

C: 66 mm

E: 26 mm