



KK1000A/1400V

HIGH POWER THYRISTOR FOR INVERTER AND CHOPPER APPLICATIONS

Features:

- . All Diffused Structure
- . Interdigitated Amplifying Gate Configuration
- . Guaranteed Maximum Turn-Off Time
- . High dV/dt Capability
- . Pressure Assembled Device

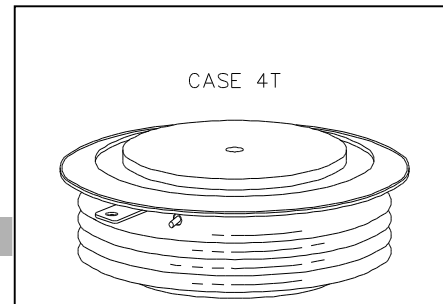

ELECTRICAL CHARACTERISTICS AND RATINGS

Blocking - Off State

Device Type	V_{RRM} (1)	V_{DRM} (1)	V_{RSM} (1)
KK1000A	1400	1400	1500

- V_{RRM} = Repetitive peak reverse voltage
 V_{DRM} = Repetitive peak off state voltage
 V_{RSM} = Non repetitive peak reverse voltage (2)

Repetitive peak reverse leakage and off state leakage	I_{RRM} / I_{DRM}	10 mA 35 mA (3)
Critical rate of voltage rise	dV/dt (4)	600V/ μ sec

Notes:

All ratings are specified for $T_j=25^\circ\text{C}$ unless otherwise stated.

- (1) All voltage ratings are specified for an applied 50Hz/60Hz sinusoidal waveform over the temperature range -40 to $+125^\circ\text{C}$.
- (2) 10 msec. max. pulse width
- (3) Maximum value for $T_j = 125^\circ\text{C}$.
- (4) Minimum value for linear and exponential waveshape to 80% rated V_{DRM} . Gate open. $T_j = 125^\circ\text{C}$.
- (5) Non-repetitive value.

Conducting - on state

Parameter	Symbol	Min.	Max.	Typ.	Units	Conditions
Average value of on-state current	$I_{T(AV)}$		1000		A	$T_c=85^\circ\text{C}$
RMS value of on-state current	I_{TRMS}		1570		A	Nominal value
Peak one cPSTC1e surge (non repetitive) current	I_{TSM}		18400		A	8.3 msec (60Hz), sinusoidal waveshape, 180° conduction, $T_j = 125^\circ\text{C}$
			16900		A	10.0 msec (50Hz), sinusoidal waveshape, 180° conduction, $T_j = 125^\circ\text{C}$
I square t	I^2t		1.66×10^6		A^2s	8.3 msec and 10.0 msec
Latching current	I_L		1000		mA	$V_D = 24\text{ V}$; $R_L = 12\text{ ohms}$
Holding current	I_H		500		mA	$V_D = 24\text{ V}$; $I = 2.5\text{ A}$
Peak on-state voltage	V_{TM}		2.9		V	$I_{TM} = 4000\text{ A}$; Duty cPSTC1e $\leq 0.01\%$
Critical rate of rise of on-state current (5, 6)	di/dt		600		A/ μ s	Switching from $V_{DRM} \leq 1000\text{ V}$, non-repetitive

KK1000A/1400V

Gating

Parameter	Symbol	Min.	Max.	Typ.	Units	Conditions
Peak gate power dissipation	P_{GM}		200		W	$t_p = 40 \mu s$
Average gate power dissipation	$P_{G(AV)}$		5		W	
Peak gate current	I_{GM}		10		A	
Gate current required to trigger all units	I_{GT}		300 150 125		mA mA mA	$V_D = 6 V; R_L = 3 \text{ ohms}; T_j = -40 \text{ }^\circ\text{C}$ $V_D = 6 V; R_L = 3 \text{ ohms}; T_j = +25 \text{ }^\circ\text{C}$ $V_D = 6 V; R_L = 3 \text{ ohms}; T_j = +125 \text{ }^\circ\text{C}$
Gate voltage required to trigger all units	V_{GT}	0.30	5 3		V V V	$V_D = 6 V; R_L = 3 \text{ ohms}; T_j = -40 \text{ }^\circ\text{C}$ $V_D = 6 V; R_L = 3 \text{ ohms}; T_j = 0-125 \text{ }^\circ\text{C}$ $V_D = \text{Rated } V_{DRM}; R_L = 1000 \text{ ohms}; T_j = +125 \text{ }^\circ\text{C}$
Peak negative voltage	V_{GRM}		5		V	

Dynamic

Parameter	Symbol	Min.	Max.	Typ.	Units	Conditions
Delay time	t_d		1.5	0.7	μs	$I_{TM} = 500 \text{ A}; V_D = \text{Rated } V_{DRM}$ Gate pulse: $V_G = 20 \text{ V}; R_G = 20 \text{ ohms}; t_r = 0.1 \mu s; t_p = 20 \mu s$
Turn-off time (with $V_R = -50 \text{ V}$)	t_q		25		μs	$I_{TM} = 1000 \text{ A}; di/dt = 25 \text{ A}/\mu s;$ $V_R \geq -50 \text{ V}; \text{Re-applied } dV/dt = 200 \text{ V}/\mu s \text{ linear to } 80\% V_{DRM}; V_G = 0;$ $T_j = 125 \text{ }^\circ\text{C}; \text{Duty cPSTC} \geq 0.01\%$
Reverse recovery charge	Q_{rr}		*	2000	μC	$I_{TM} = 1000 \text{ A}; di/dt = 25 \text{ A}/\mu s;$ $V_R \geq -50 \text{ V}$

* For guaranteed max. value, contact factory.

THERMAL AND MECHANICAL CHARACTERISTICS AND RATINGS

Parameter	Symbol	Min.	Max.	Typ.	Units	Conditions
Operating temperature	T_j	-40	+125		$^\circ\text{C}$	
Storage temperature	T_{stg}	-40	+150		$^\circ\text{C}$	
Thermal resistance - junction to case	$R_{\Theta(j-c)}$		0.023 0.046		$^\circ\text{C}/\text{W}$	Double sided cooled Single sided cooled
Thermal resistance - case to sink	$R_{\Theta(j-c)}$		0.010 0.020		$^\circ\text{C}/\text{W}$	Double sided cooled * Single sided cooled *
Mounting force	P	19.5	21		kN	

* Mounting surfaces smooth, flat and greased

Note : for case outline and dimensions, see case outline drawing in page 3 of this Technical Data

KK1000A/1400V

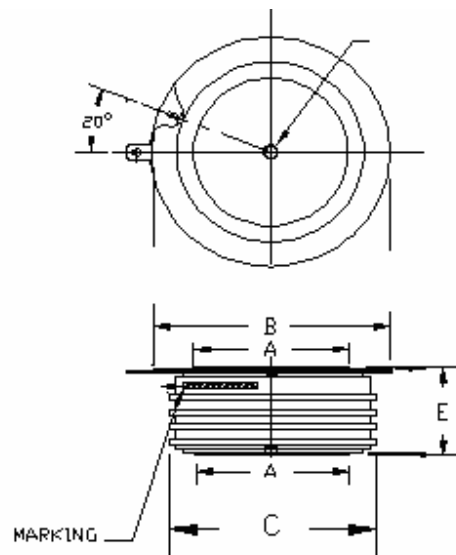

A: 47 mm

B: 74 mm

C: 66 mm

E: 26 mm