

Universal Motor - UG Series

Voltage : 100 - 240V AC (50/60 Hz)
 Rated Speed : 10000 - 20000 rpm
 Insulation Class : A, E, B
 Typical Applications : Blender, Juicer Extractor, Food Processor,
 Meat Grinder, Drink Mixer, Grass Trimmer, Pump
 Also available with commercial grade, details refer to P.36 and 37.

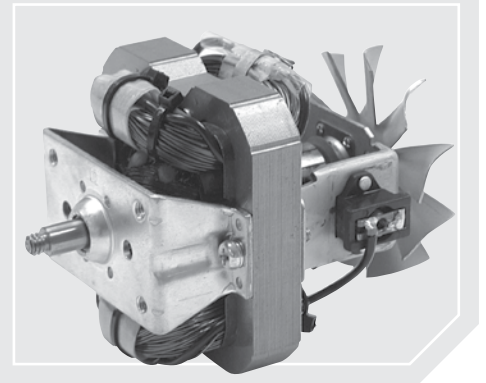

Performance Curve

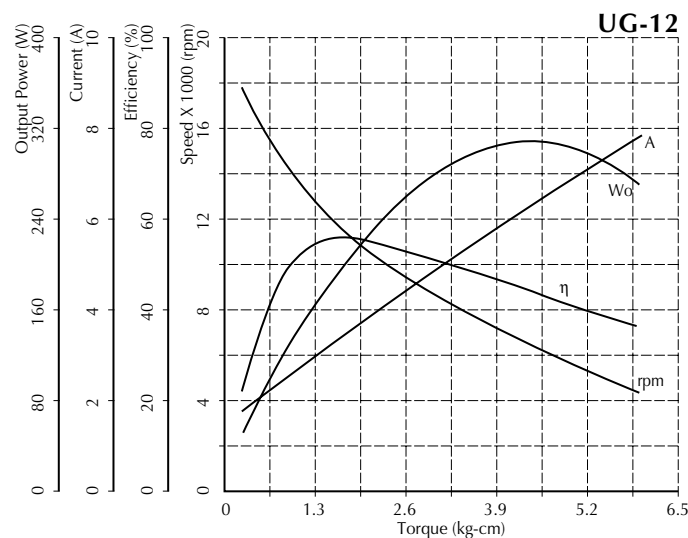

Dimension (mm)

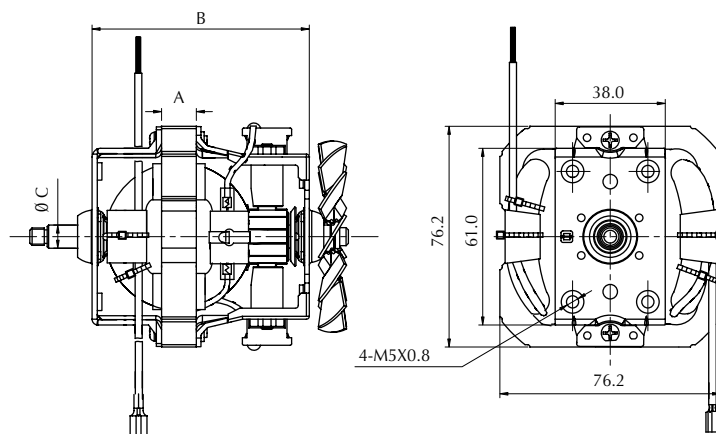

Performance (testing under room temperature)

Model	Dim A	Dim B	Dim C	Rated Torque/ kg-cm	Rated Input Power/ W
UG-12	12	75	8.0 / 10.0	1.00 - 2.00	300 - 450
UG-15	15	80	8.0 / 10.0	1.00 - 3.00	350 - 550
UG-20	20	85	8.0 / 10.0	1.50 - 3.50	400 - 600
UG-25	25	90	8.0 / 10.0	2.00 - 5.00	500 - 850
UG-30	30	95	8.0 / 10.0	2.00 - 6.00	650 - 1200

The information above is for reference only, detailed specification is subject to final confirmation