

Customer Specification File

Customer:

Project : ETSI TS 101 952-1-1 Option A Filter for ADSL2+ Application

Request from :

Magcom PN: ACP270P01-05

Revision	Realized By	Modification Description	Date	Last Pages
A01	Kelvin Huang	New Release	July-13-2006	8

Table of contents

1 Preliminary	4
2 Customer reference documents	4
3 Standard reference documents	4
4 Features	4
5 Design requirements	5
5.1 Schematic	5
5.2 Electrical Performance	5
5.3 Mechanical.....	7
5.4 Pin Assignments	7
6 Environmental conditions:	8
6.1 Resistibility to over voltages and over currents:.....	8
6.2 Climatic conditions:.....	8
7 Reliability conditions:	8
7.1 Thermal shock:.....	8
7.2. Temperature humidity exposure:.....	8
7.3. Vibration test:.....	8
8 Note	8

1 Preliminary:

This is a Customer design project for URMET. This Document is for Specification Review

2 Customer reference documents:**3 Standard reference documents:**

- ETSI TS 101 952-1-1
- ETSI TS 101 952-1-2
- ITU-T G.992.5 Annex E (ADSL2+)
- ITU-T K21

4 Features (Blank)

5 Design Requirement

5.1 Schematic

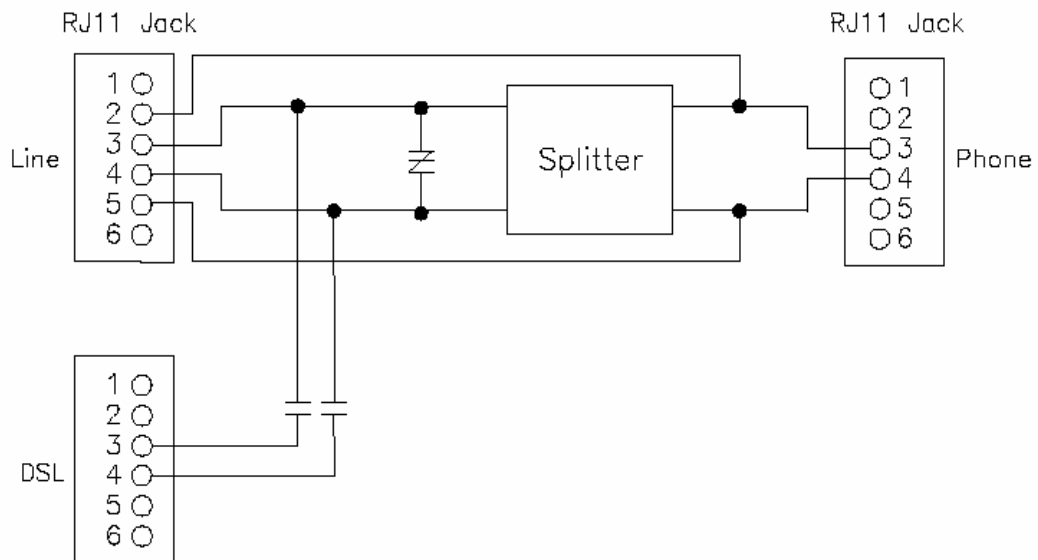

5.2 Electrical Performance

5.2.1 General conditions

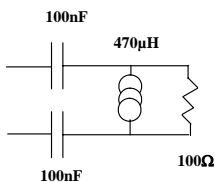
General conditions		
	Conditions	Values
Splitter bandwidth		DC-16KHz
Voice band		DC-4KHz
Ringing frequency		25Hz ~ 50Hz
ADSL frequency band		30KHz ~ 2.2MHz
POTS band impedance-Z _R	0Hz ~ 4KHz	270 Ω + (750 Ω // 150nF)
POTS band impedance-Z _{SL}	0Hz ~ 4KHz	82 Ω + (600 Ω // 68 nF)
Z _{ADSL}	0Hz ~ 4KHz	
ADSL band impedance Z _{RHF}	30KHz~2.2MHz	120Ω + (150Ω // 47nF)+ (750Ω //150nF)
Modem impedance	30KHz~2.2MHz	100Ω
Max. operating voltage to ground		250VDC
DC Loop current		<80mA

5.2.2 Electrical Requirement

Electrical Requirement		
DC requirements		
	Conditions	Values
TIP and RING to Earth	100VDC	> 20 MΩ
TIP to RING	100VDC	> 5 MΩ
TIP to RING	POTS port shorted	<50Ω
Voice band loss requirements		
Insertion loss	Z _R / @1004Hz	<1.0 dB
Insertion loss	600Ω/ @1004Hz	<1.0 dB
Option A Return loss	Z _R /300 Hz to 3.4 kHz	>12 dB
	Z _R /3.4kHz to 4.0 kHz	>8 dB
	Z _{SL} /300 Hz to 3.4 kHz	>12 dB
	Z _{SL} /3.4kHz to 4.0 kHz	>8 dB
Group delay distortion Z _R & 600 Ω	0.6 kHz to 3.2 kHz	< 200 us
	0.2 kHz to 4.0 kHz	< 250 us
Intermodulation distortion Z _R	2 nd	> 57 dB
	3 nd	> 60 dB
Unbalance about Earth	50Hz to 600Hz	< 40 dB
	600Hz to 3400Hz	< 46 dB
	3400Hz to 4KHz	< 40 dB
	4KHz to 30KHz	< 40 dB
	30KHz to 1104KHz	< 45 dB
	1104K to 2.2MHz	< 30 dB
POTS transient effects		< 2Vp-p, <15KHz
ADSL band requirements		
Stop band attenuation Z _{RHF}	32kHz~2.2MHz	>55dB

5.3 Mechanical

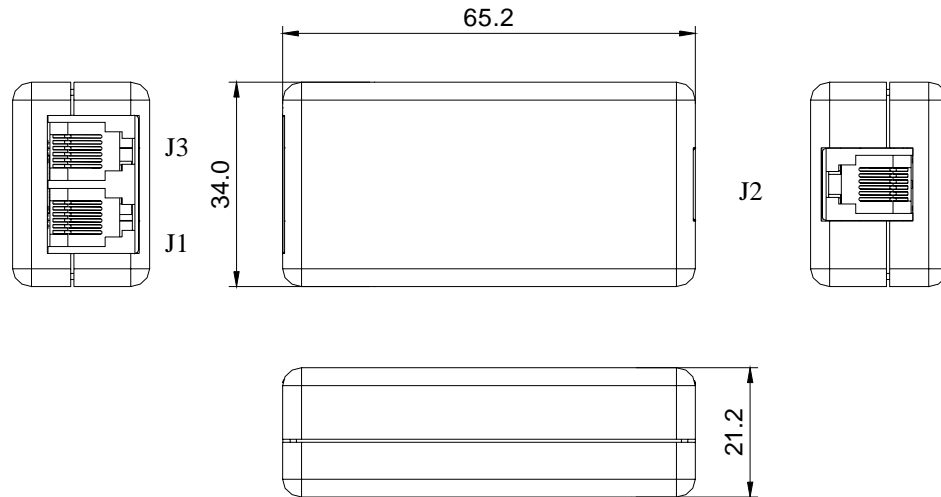

5.4 Pin Assignments

Connector	Function	Style	Tip	Ring
J3	Modem	RJ11	Pin3	Pin4
J2	Line	RJ11	Pin3	Pin4
J1	Phone	RJ11	Pin3	Pin4

6 Environmental conditions:

6.1 Resistibility to over voltages and over currents:

Comply with the resistibility requirements per ITU-T Recommendation K.20 electrical safety requirements

6.2 Climatic conditions:

6.2a. Operating temperature:

-20 °C to +60°C

6.2b. Storage and transportation:

Low ambient temperature - 40°C

High ambient temperature +80°C

6.2c. Operation humidity:

0 to 95% (non-condensing)

7 Reliability conditions:

7.1 Thermal shock:

Temperature from -20 °C to +85 °C for 5 cycles

7.2. Temperature humidity exposure:

+50 °C / 95 RH, 96hrs

7.3. Vibration test:

Random vibration / Overall: 1.15 g rms

Freq. (Hz): 1 → 4 → 100 → 200

PSD (g₂/ Hz): 0.0001 → 0.01 → 0.01 → 0.001

Test Axis / Time: Top / 30 mins Bottom / 10 mins

X axis / 10 mins Y axis / 10 mins

8 Note: