

DK 系列离心泵 SERIES CENTRIFUGAL PUMPS



WORKING CONDITIONS

Max Temperature of Fluid up to +80°C
Max Pressure 10bar,
Max Ambient Temperature up to 40°C

工作条件：

最高流体温度为80℃
最大可承受的压力10bar
最高环境温度40℃

DK pumps are recommended for pumping water and chemically non-aggressive liquid. With an open impeller, DK pumps are designed pumping fairly large amounts of impurities without fault of clogging, suitable for irrigation, industrial applications, etc. As with impeller cantilevered on the motor shaft directly, the DK pumps have a compact size, very reliable, simple to use and almost maintenance-free, It can be installed horizontally or vertically.

DK 系列为单级半开式叶轮的离心电泵，适用于家庭、农户、企事业给排水，可用于输送含有杂质的水或其它类似的不具腐蚀性的流体，不产生堵塞。其水力特性为中等扬程中等流量。



H m PERFORMANCE CHART AT n=2900r/min 折算到2900r/min时性能

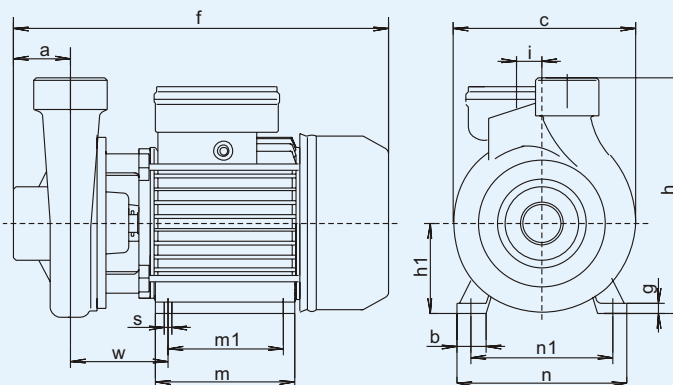
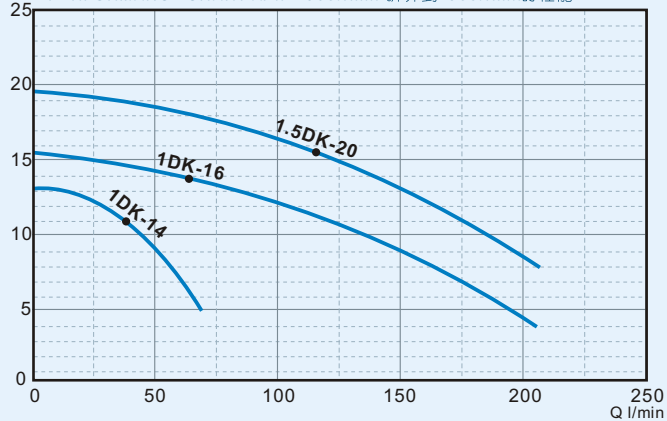

DIMENSIONS 安装尺寸

TYPE 型号	Dimensions 外形尺寸 mm														Weight 重量 (kg)		Packing Size 包装尺寸 (mm)			Packing QTY. 包装数量
	a	f	h	c	H1	i	m	m1	n	n1	w	b	g	s	NW	GW	L	W	H	20' Cont 20'柜
1DK14	42	270	160	120	63	10	100	80	120	100	72	23	8	9	7.2	7.8	305	175	205	2500
1DK20	45	296	186	145	71	20	110	90	135	112	77	25	9	10	11.8	12.6	310	175	210	1800
1.5DK20	45	296	186	150	71	20	110	90	135	112	77	25	9	10	13.7	14.7	370	195	230	1800

TECHNICAL DATA 技术参数

TYPE 型号	Output Power 输出功率		Current 电流 (A)	Capacitor 电容器 (F)	H.max 最高扬程 (m)	Q.max 最大流量 (l/min)	Size 进出口径 (inch)	S.Head 最大吸程 (M)	Total head (m) 总扬程	Capacity 流量 l/min							
	KW	HP								30	40	50	80	150	200		
1DK14	0.25	0.33	1.8	8	13	72	1"X1"	7	Total head (m) 总扬程	11	10	9	-	-	-	-	
1DK20	0.55	0.75	3.7	16	16	210	1"X1"	7		15	14.5	14.5	12.5	8	4	-	-
1.5DK20	0.75	1	4.6	20	20	210	1.5"X1.5"	7		-	18	18	16	13	8	-	-

标准的电参数及零件配置：单相220V/50Hz、铜叶轮、碳钢轴、马达内置热保护器。可根据客户的其它参数及材料的要求，制作其它单、三相电压、60Hz、双电压、不锈钢轴等规格的产品。
Standard data and equipment: single phase 220V/50Hz, Brass impeller, carbon steel motor shaft, with terminal protector inside.
Others model and material such as three phase, 110V, 60Hz, dual voltage, stainless steel shaft, etc, will be available upon request.