



POSITIONING

R395CH_x - Power Thyristor

1400 - 2100 V_{DRM}; 1275 A rms

HIGH POWER THYRISTOR FOR INVERTER *AND CHOPPER APPLICATIONS

Features:

- . All Diffused Structure
- . Interdigitated Amplifying Gate Configuration
- . Blocking capability up to 2100 volts
- . Guaranteed Maximum Turn-Off Time
- . High dV/dt Capability
- . Pressure Assembled Device

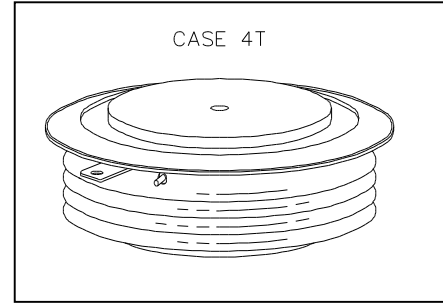

ELECTRICAL CHARACTERISTICS AND RATINGS

Blocking - Off State

Device Type	V _{RRM} (1)	V _{DRM} (1)	V _{RSM} (1)
R395CH14	1400	1400	1500
R395CH18	1800	1800	1900
R395CH21	2100	2100	2200

V_{RRM} = Repetitive peak reverse voltage
V_{DRM} = Repetitive peak off state voltage
V_{RSM} = Non repetitive peak reverse voltage (2)

Repetitive peak reverse leakage and off state leakage	I _{RRM} / I _{DRM}	20 mA 65 mA (3)
Critical rate of voltage rise	dV/dt (4)	500 V/μsec

Notes:

All ratings are specified for T_j=25 °C unless otherwise stated.

- (1) All voltage ratings are specified for an applied 50Hz/60Hz sinusoidal waveform over the temperature range -40 to +125 °C.
- (2) 10 msec. max. pulse width
- (3) Maximum value for T_j = 125 °C.
- (4) Minimum value for linear and exponential waveshape to 80% rated V_{DRM}. Gate open. T_j = 125 °C.
- (5) Non-repetitive value.
- (6) The value of di/dt is established in accordance with EIA/NIMA Standard RS-397, Section 5-2-2-6. The value defined would be in addition to that obtained from a snubber circuit, comprising a 0.2 μF capacitor and 20 ohms resistance in parallel with the thyristor under test.

Conducting - on state

Parameter	Symbol	Min.	Max.	Typ.	Units	Conditions
Average on-state current.	I _{TRMS}		1275		A	T _c = 55 °C
Peak one cycle surge (non repetitive) current	I _{TSM}		15500		A	10.0 msec (50Hz), sinusoidal waveshape, 180° conduction, T _j = 125 °C
I square t	I ² t		1.2x10 ⁶		A ² s	10.0 msec
Holding current	I _H		1000		mA	V _D = 24 V; I = 2.5 A
Peak on-state voltage	V _{TM}		1.9		V	I _{TM} = 2000 A; Duty cycle ≤ 0.01%
Critical rate of rise of on-state current (5, 6)	di/dt		1500		A/μs	Switching from V _{DRM} ≤ 1000 V, non-repetitive
Critical rate of rise of on-state current (6)	di/dt		1000		A/μs	Switching from V _{DRM} ≤ 1000 V

ELECTRICAL CHARACTERISTICS AND RATINGS (cont'd) R395CHx - Power Thyristor

Gating

Parameter	Symbol	Min.	Max.	Typ.	Units	Conditions
Peak gate power dissipation	P_{GM}		30		W	$t_p = 40 \mu s$
Average gate power dissipation	$P_{G(AV)}$		5		W	
Peak gate current	I_{GM}		10		A	
Gate current required to trigger all units	I_{GT}		300		mA	$V_D = 6 V; R_L = 3 \text{ ohms}; T_j = +25 \text{ }^\circ C$
Gate voltage required to trigger all units	V_{GT}		3		V	$V_D = 6 V; R_L = 3 \text{ ohms}; T_j = +25 \text{ }^\circ C$
Peak negative voltage	V_{GRM}		5		V	

Dynamic

Parameter	Symbol	Min.	Max.	Typ.	Units	Conditions
Delay time	t_d		1.5	0.7	μs	$I_{TM} = 500 A; V_D = \text{Rated } V_{DRM}$ Gate pulse: $V_G = 20 V; R_G = 20 \text{ ohms}; t_r = 0.1 \mu s; t_p = 20 \mu s$
Turn-off time (with $V_R = -50 V$)	t_q		65		μs	$I_{TM} = 1000 A; di/dt = 60 A/\mu s;$ $V_R \geq -50 V; \text{Re-applied } dV/dt = 200 \text{ V}/\mu s \text{ linear to } 80\% V_{DRM}; V_G = 0;$ $T_j = 125 \text{ }^\circ C; t_p = 1 \text{ ms}$
Reverse recovery charge	Q_{rr}		*	940	μC	$I_{TM} = 1000 A; di/dt = 60 A/\mu s;$ $V_R \geq 50 V$

* For guaranteed max. value, contact factory.

THERMAL AND MECHANICAL CHARACTERISTICS AND RATINGS

Parameter	Symbol	Min.	Max.	Typ.	Units	Conditions
Operating temperature	T_j	-40	+125		$^\circ C$	
Storage temperature	T_{stg}	-40	+150		$^\circ C$	
Thermal resistance - junction to case	$R_{\Theta(j-c)}$		0.023 0.046		$^\circ C/W$	Double sided cooled Single sided cooled
Thermal resistance - case to sink	$R_{\Theta(j-c)}$		0.010 0.020		$^\circ C/W$	Double sided cooled * Single sided cooled *
Mounting force	P	5500 24.5	6000 26.7		lb. kN	
Weight	W			16 460	oz. g	

* Mounting surfaces smooth, flat and greased

Note : for case outline and dimensions, see case outline drawing in page 3 of this Technical Data

CASE OUTLINE AND DIMENSIONS.

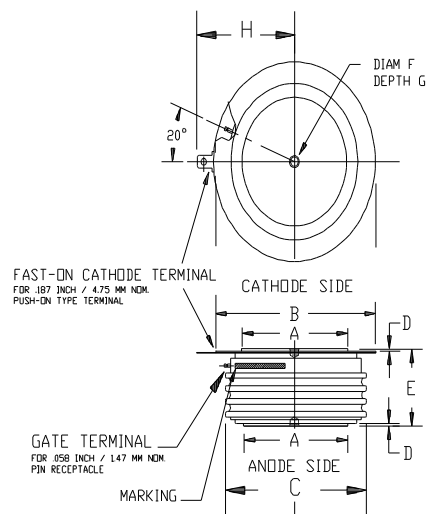

STRIBE DISTANCE = .58 INCH / 14.7 MM MIN.
CREEPAGE DISTANCE = 1.00 INCH / 25.4 MM MIN.

OUTLINE DIMENSIONS - CASE 4T				
DIMENSIONS	Min. mm	Max. mm	Min. In.	Max. In.
DIAM A	43.18	48.26	1.70	1.90
DIAM B	63.50	75.18	2.50	2.96
DIAM C	--	67.31	--	2.65
D	0.76	--	0.03	--
E	25.40	27.18	1.00	1.07
F	3.30	3.81	0.13	0.15
G	1.78	2.03	0.07	0.08
H	--	44.20	--	1.74