

LED SPOTLIGHT



EP-E27-3 3W 5W

EAGLE POWER

INTERNATIONAL HOLDINGS (HK)LTD

E27-3 3W,5W

Production Specification

- ✓ Long Life, High security, High reliability
- ✓ Low dissipation, Low heat, Low power consumption

■ TYPICAL APPLICATIONS

- Residential and commercial lighting/illumination.
- Museum, art gallery, hotel, furniture decoration, cabinet light, supermarket, cosmetic shops where UV or IR radiation is undesirable.

■ FEATURES

- Highly efficient light out with very low power consumption.
- Scientific design with thermolysis function
- Using aluminium, ceramic and other raw materials.
- Optional input voltage
- Long service life, the average life span is above 30000 hours.
- CE & RoHS approvals

■ OPERATING ENVIRONMENT

Item	Rating	Unit
Operating frequency	50~60	HZ
Bulb temperature	40~60	°C
Storage temperature....	-40~85	°C

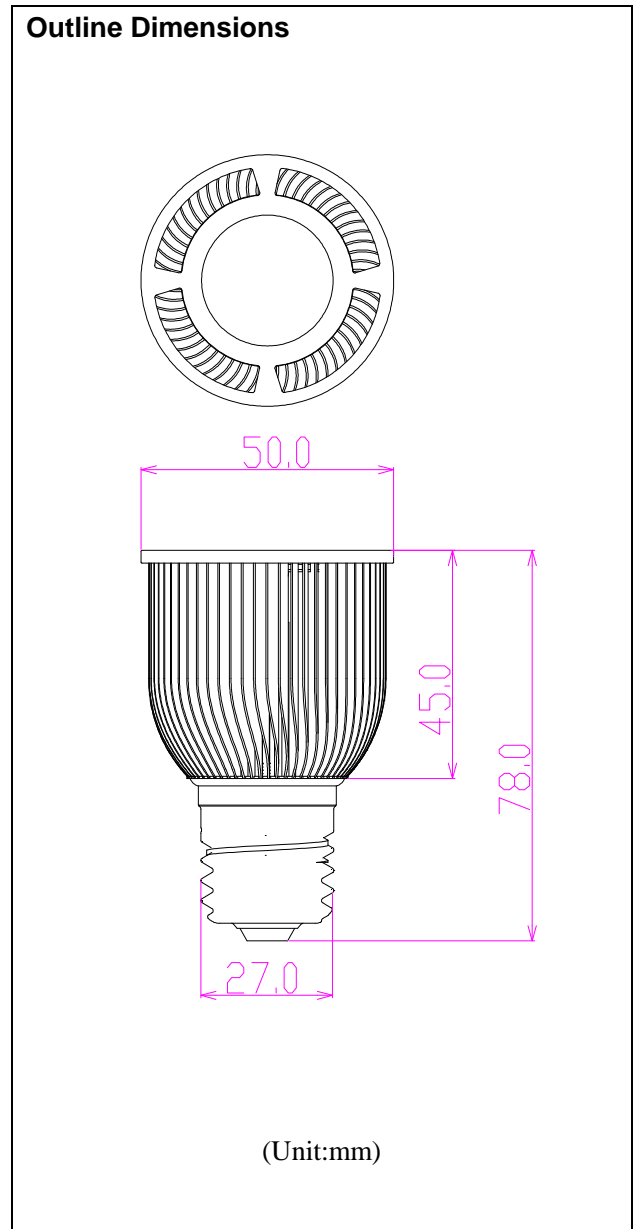

**■ ELECTRICAL AND OPTICAL CHARACTERISTICS (Ta= 25°C)**

part number	Emitted Color	Viewing Angle (deg)	Total power (W)	Luminous (lm)	led qty (pcs)	voltage
EP-A1S03001C3-E27	white	55	3W	150	1	AC80 -265V
EP-A1W03001C3-E27	Warm white	55	3W	120	1	AC80 -265V
EP-A1R03001C3-E27	red	55	3W	120	1	AC80 -265V
EP-A1G03001C3-E27	green	55	3W	150	1	AC80 -265V
EP-A1B03001C3-E27	blue	55	3W	45	1	AC80 -265V
EP-A1Y03001C3-E27	yellow	55	3W	90	1	AC80 -265V
EP-A1S05001C3-E27	white	55	5W	120	1	AC80 -265V
EP-A1W05001C3-E27	Warm white	55	5W	100	1	AC80 -265V

■ DESCRIPTIONS

Base type: E27-3 3W,5W

Net Weight: 94g

Chif Matural: Aluminium/ Ceramic

Color of the bulb: all kinds of colors ,which can be follow customer's requirements.

Voltage range: Input voltage can be at AC80 -265V

■ CAUTIONS FOR USE

- ◆ Handle with care.
- ◆ Don't place the products in the damp environment.
- ◆ Don't touch the metal parts of the light while the power is on.
- ◆ If it is used in outdoors,it should be add waterproof in consideration.



EAGLE POWER INTERNATIONAL HOLDINGS (HK) LIMITED

HK OFFICE:

Add : Rm 501A. 12/F., Independent Building, 499-501 Nathan Road, Kowloon, HongKong
Web : www.sbcds.com.cn/en
E-mail : saleshk@sbcds.com.cn
Tel : 852-2332-9637 2332-8735
Fax : 852-2332-5706

SHENZHEN OFFICE:

Add : No.4 Building,HuaWan Industry Area, BaoAn ,ShenZhen, China
E-mail : salessz@sbcds.com.cn
Tel : 86-755-29644732
Fax : 86-755-27890140