



东一部品仕样承认书

APPROVAL SHEET

客 户 CUSTOMER	
客户产品编码/规格 PRODUCT SPECIFICATION	
品 名 PART NAME	检测开关
型 号 MODEL	DS-1120A
制 样 DSGD BY	叶玉兰
审 核 CHKD BY	富 胜
担 当 APPD BY	富 胜
送 样 日期 SENDING DATE	日期:
承认印 APPD PRINT	

深 圳 市 东 一 部 品 电 子 有 限 公 司

TONES PARTS ELECTRONICS CO.,LTD

ADD: 深圳市龙岗区坪地镇黄竹工业区

HUANGZHU INDUSTRIAL PARK PINGDI TOWN

LONGGANG AREA SHENZHEN CITY CHINA

TEL: 0755-84091585 84090865

FAX: 0755-84090796

HTTP: //www.e-hanxing.com

E-mail:root@e-hanxing.com

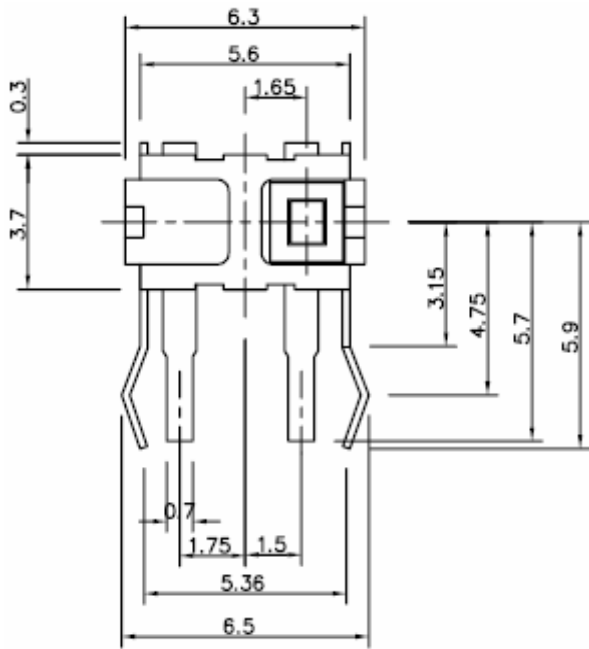

P.C.board mounting hole

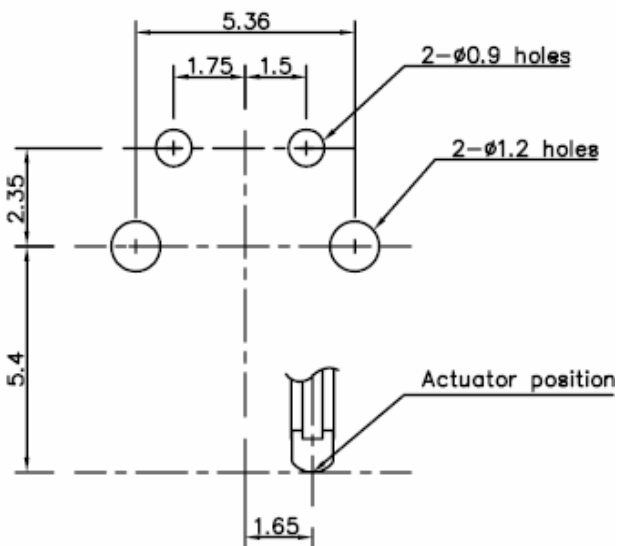

CIRCUIT DIAGRAM

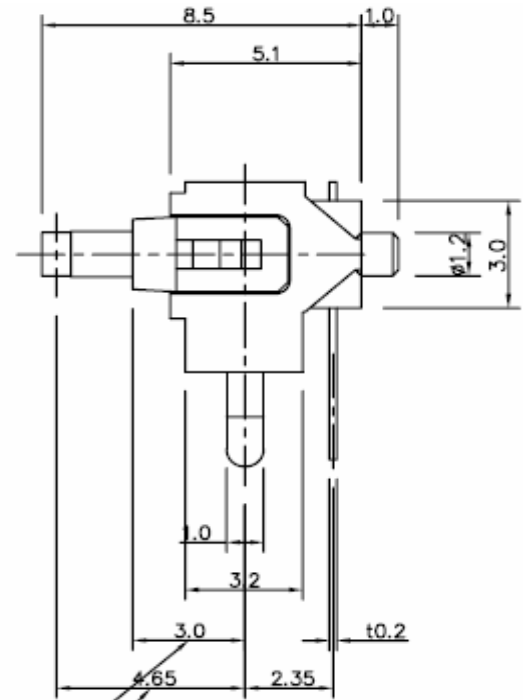

Full travel

ON starting position

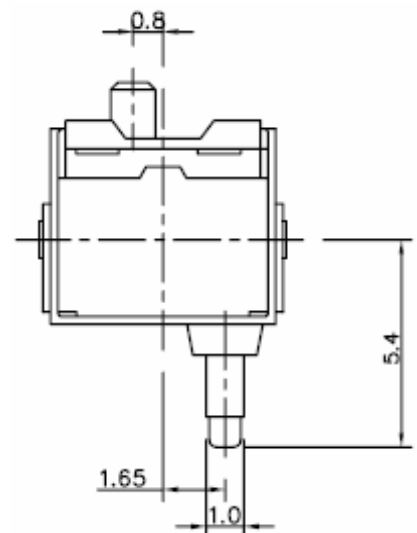

SPECIFICATION

- 1.RATING :DC 30V 100mA
- 2.OPERATING FORCE : 36gf Max.
- 3.CONTACT RESISTANCE : 1ΩMax.
- 4.LIFE : 50,000cycles

公差: 0~4: ±0.1; 4~16: ±0.15; 16~64: ±0.25mm

检测开关
DETECTOR SWITCH

型号

DS-1120A

图号

标记 处数 更改文号 签名 日期 数量 质量 比例 04:01

设计/日期 李建强 2004.9.1

校对/日期 李建强 2004.9.1 审核/日期 张云 2004.9.1

工艺/日期 李建强 2004.9.1 批准/日期 富胜 2004.9.1

东一部品电子有限公司
TONE PARTS ELECTRONICS CO., LTD

SPECIFICATION

DESCRIPTION	DETECTOR SWITCH	DATE	SEP.27,04	WRT'T	CHK'D	APP'D
MODEL NO.		PAGE	1 OF 5			

1. GENERAL

1.1 Application: This specification is applied to low current detector switch used for electronic equipment.

1.2 Operating temperature range: -10~60°C

1.3 Test condition: Unless otherwise specified the atmospheric for making measurement and tests are as follows.

1.3.1 Ambient temperature: 5~45°C

1.3.2 Relative humidity: 45~85°C

1.3.3 Air pressure: 86~106KPA (860~1060millibar) should any doubt arise in Judgment, tests shall be conducted at the following conditions.

2. APPEARANCE (CONSTRUCTION AND DEMENSIONS)

2.1 Appearance: Switch shall have good finishing and no rust, crack of plating failures.

2.2 Construction and dimensions: Refer to individual drawing.

2.3 Marking: Refer to individual drawing.

3. RATING: 30V DC 0.1A(Resistive load)

4. ELECTRICAL SPECIFICATION

	ITEMS	TEST CONDITIONS	CRITERIA
4.1	Contact resistance	Shall be measured at 1KHz \pm 200Hz(20mV max,50mA max) or 1A,5V DC by voltage drop method.	1 Ω MAX
4.2	Insulation resistance	Test voltage: 100V DC Measured after 1min \pm 5 sec Applied position: Between all terminals Between terminals and ground (frame)	100 M Ω MIN
4.3	Voltage proof	Test voltage: 100V AC (50~60Hz, cut-off current 2mA) Duration: 1min Applied position: Between all terminals, between terminals and ground (frame)	No dielectric breakdown shall occur.

5.MECHANICAL SPECIFICATION

5.1	Operating force	A static load shall be applied to the tip of actuator operating direction	Refer to individual drawing
5.2	Robustness of terminal	A static load of 3N(306gf) shall be applied to the tip of terminal in desired direction for 1 min. The test shall be done once per terminal.	Shall be free from terminal looseness. Damage and breakage of terminal holding Portion terminals may be bent after test. Electrical performance requirement specified in item 4 shall be satisfied.
5.3	Robustness of actuator	A static load of 10N(1.02gf) shall be applied to the operating direction of actuator for 15 sec.	Shall be free from pronounced wobble deformation and mechanical abnormalities.
		A static load of 3N(306gf) shall be applied in the pull direction of actuator for 15 sec.	
		A static load of 3N(306gf) shall be applied in the perpendicular direction of operation at the tip of actuator for 15 sec.	
5.4	Wobble of actuator	Run-out(p-p) shall be measured by applying a static load of 0.5N(51gf) in the vertical direction of operation at the tip of actuator.	P-P: 1mm max
5.5	Solder ability	Switch shall be checked after following test. (1) Solder: H63A(JIS Z3282) (2) Flux: Rosin flux(JIS K5902) having a nominal composition of 25% solid by weight of water white rosin in methyl alcohol(JIS K1501) solution (3) Soldering temperature: $230 \pm 5^{\circ}\text{C}$ Immersing time: 3 ± 0.5 sec Flux immersing time shall be 5~10 sec.	More than 90% of Immersed part shall be covered with solder

5.6	Soldering heat resistance	<p>Switch shall be measured after following test</p> <p>(1) Solder: H63A(JIS Z3282)</p> <p>(2) Flux: Rosin flux(JIS K5902) having a normal-Al composition of 10% solids by weight of Water white rosin in methyl alcohol(JIS K1501) solution.</p> <p>(3) Temperature and immersing time Dip soldering: $255 \pm 5^{\circ}\text{C}$, 3 ± 1 sec</p> <p>(4) Immersion depth: Immersion depth shall be at Copper plating portion for P.C.B terminal after mounting.</p> <p>(5) Thickness of P.C.B :1.6mm (Single sided copper clad P.C.B)</p>	<p>No abnormalities shall be recognized in appearance.</p> <p>The electrical performance recurrent specified in item 4 shall be satisfied.</p>
5.7	Shock resistance	<p>Switch shall be measured after test with following conditions:</p> <p>(1) Normal mounting method</p> <p>(2) Duration: 11MS</p> <p>(3) Test direction: 6 directions</p> <p>(4) Numer of shock: 3 times per direction</p>	<p>Contact resistance :1 Ω max</p> <p>Operating resistance :within specified value shall be free from mechanical abnormalities</p>
5.8	Vibration resistance	<p>The test is conducted by a regular mounting device and following method:</p> <p>(1) Vibration frequency range: 10~55Hz</p> <p>(2) Total amplitude: 1.5mm</p> <p>(3) Sweep ratio: 10~55-10Hz,1 minute</p> <p>(4) Method of changing the sweep vibration frequency: Logarithmic or linear</p> <p>(5) Direction of vibration: 3 directions including Actuator</p> <p>(6) Time: 2 hours each</p>	<p>Contact resistance :1 Ω max</p> <p>Insulation resistance :100MΩ max</p> <p>Voltage proof :Applying 100V DC for 1 min</p> <p>No dielectric breakdown shall occur operating force: within specified value</p>

6.DURABILITY

6.1	Operating life	<p>(1) With load: 50,000 cycles operation at a rate of 15~20 cycle/min. With a resistive load supplying 30V DC,0.1A</p> <p>(2) Without load: 50,000 cycles operations at a rate of 15~20 cycle/min. Without load</p>	<p>Contact resistance : 1Ω max Insulation resistance : 10MΩ min Operating force : Within specified value Voltage proof: Applying 100V DC for 1 minute.</p>
-----	----------------	--	--

7. WEATHER PROOF

7.1	Cold heat proof	<p>After testing at $-20 \pm 2^{\circ}\text{C}$ for 96 hours, the switch shall be allowed to stand under normal temperature and humidity condition For 1 hour and then measurement shall be made within 1 hour. Water drops shall be removed.</p>	
7.2	Dry heat proof	<p>Afer testing at $85 \pm 2^{\circ}\text{C}$ for 96 hours, the switch shall be allowed to stand under normal temperature and humidity conditions for 1 hour and then measurement shall be made within 1 hour.</p>	<p>Contact resistance : 2Ω max Insutation resistance : 10MΩ min Voltage proof : Applying 100V AC for 1 minute. No dielectric breakdown shall occur.</p>
7.3	Damp heat proof	<p>After testing at $40 \pm 2^{\circ}\text{C}$ and 90~95%RH for 96 hours, the switch shall be allowed to stand under normal temperature and humidity conditions for 1 hour and measurement shall be made within 1 hour after that. Water drops shall be removed.</p>	<p>Operating force: Within specified value tno abnormalities in appearance and constru- ction shall be recog- nized.</p>
7.4	Damp heat With load (silver migration)	<p>DC voltage 1.5 times as much as rated voltage shall be applied continually between adjacent terminal at $60 \pm 2^{\circ}\text{C}$ and 90~95%RH. After 500 hours testing: switch shall be allowed to stand under normal temperature and humidity condition for 1 hour ,and measurement shall be made within 1 hour after that. Water drops shall be removed.</p>	<p>The requirement in item 3 and 4 shall be made.</p>

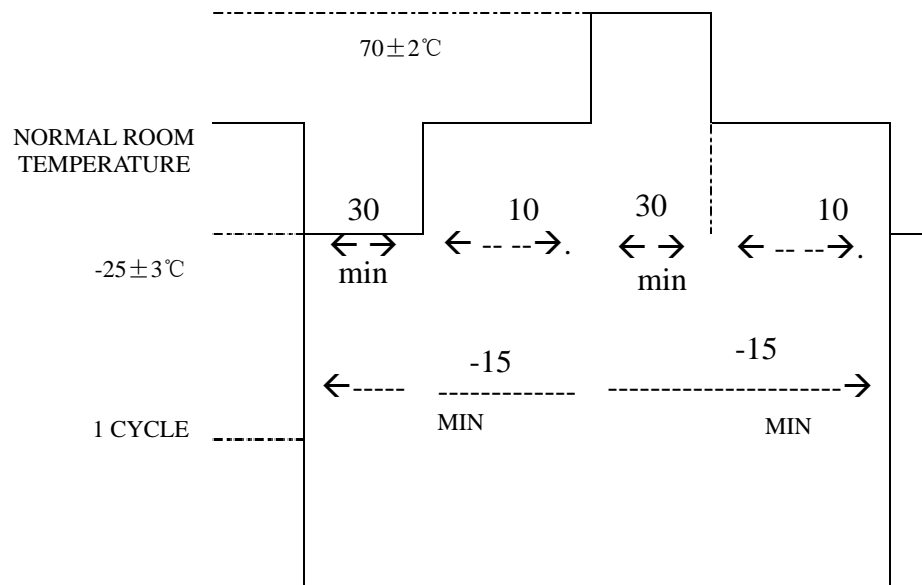

After 5 cycles of following conditions, the switch shall be allowed to stand under normal temperature and humidity conditions for 1 hour and measurement shall be made within 1 hour after that.

Water drops shall be removed.

8.PRECAUTION IN USE

8.1 Note that if load is applied to the terminals during soldering they might suffer deformation and defects in electrical performance.

8.2 Use of water-soluble flux shall be avoided because it may cause corrosion of the switch.