

CHINA DISPLAY TECHNOLOGY CO., LTD.

深圳市新深辉显示技术有限公司

SPECIFICATION

Product No.: **SVM802BSFA-1**

Customer: _____

Issue Date: **October 10, 2005**

CHINA DISPLAY TECH.		
APPROVED	CHECKED	PREPARED

Block 513,4,5,6th Floor Bagualing Industrial Area Shenzhen , China
TEL: 0086-755-25843714
FAX: 0086-755-82262915

CHINA DISPLAY TECHNOLOGY CO., LTD.

Data	Sheet No.	Summary
		NEW

Table Of Contents

Section/Sub Section	Pages	Rev.
1 General Description	3	0
2 Mechanical Diagram	4	0
3 I/O Terminal	5	0
3.1 Pin Description	5	0
3.2 Block Diagram	6	0
4. Timing Characteristics	6	0
5. Code Description	8	0
6 .Electro-Optical Characteristics	9	0
6.1 Electro-Optical Characteristics Test	9	0
6.2 Definition of Operating Voltage, Vop	9	0
6.3 Definition of Optical Response Time	10	0
6.4 Definition of Viewing Angle θ and φ	10	0
6.5 Definition of Contrast ratio, CR	11	0
6.6 Reliability Test	11	0
7 Precautions for Using LCD Module	12	0
7.1 Handing Precautions	12	0
7.2 Others	13	0
8 Using LCD Modules	13	0
8.1 Liquid Crystal Display Modules	13	0
8.2 InstallingLCD Module	14	0
8.3 Electro-Static Discharge Control	14	0
8.4 Precaution For Soldering To The LCM	14	0
8.5 Precaution For Operation	15	0
8.6 Storage	15	0
8.7 Safety	15	0
8.8 Limited Warranty	16	0

CHINA DISPLAY TECHNOLOGY CO., LTD.

2 Mechanical Diagram

PIN FUNCTION

Pin No.	Symbol	Pin No.	Symbol
1	GND	9	DB2
2	VDD	10	DB3
3	VLCD	11	DB4
4	RS	12	DB5
5	R/W	13	DB6
6	E	14	DB7
7	DB0		
8	DB1		

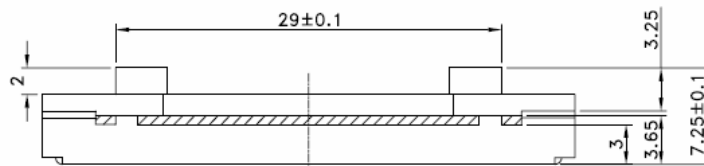
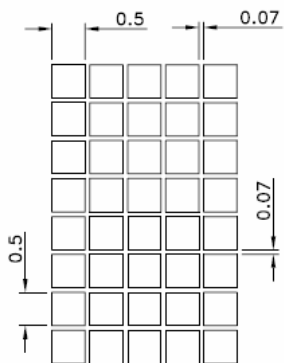
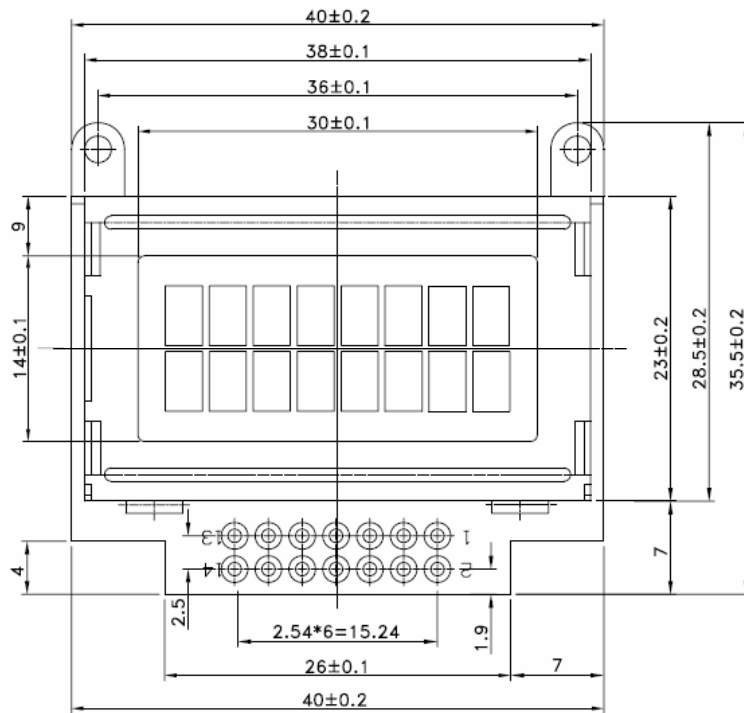
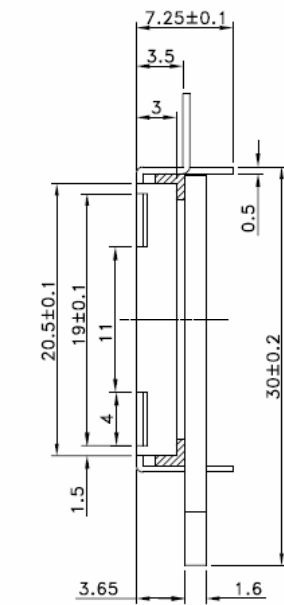
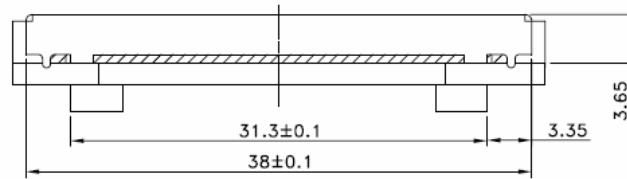

SVM802BSFA-1

CHINA DISPLAY TECHNOLOGY CO., LTD.

3 I/O Terminal

3.1 Pin Description

NO.	SYMBOL	I/O	FUNCTION
1	GND	I	Ground
2	VDD	I	Power input.
3	VLCD	I	Negative Voltage for LCD driving.
4	RS	I	A signal for selecting registers. 1:Data Register(for read and write). 0:Instruction Register(for write). Busy flag-Address Counter (for read).
5	R/W	I	A signal for selecting read or write actions. 1:Read 0:Write
6	E	I	A start signal for reading or writing data.
7~ 14	DB0~DB7	I/O	Data bit 0—Data bit 7
15	A	I	LED+
16	K	I	LED-

3.2 Block Diagram

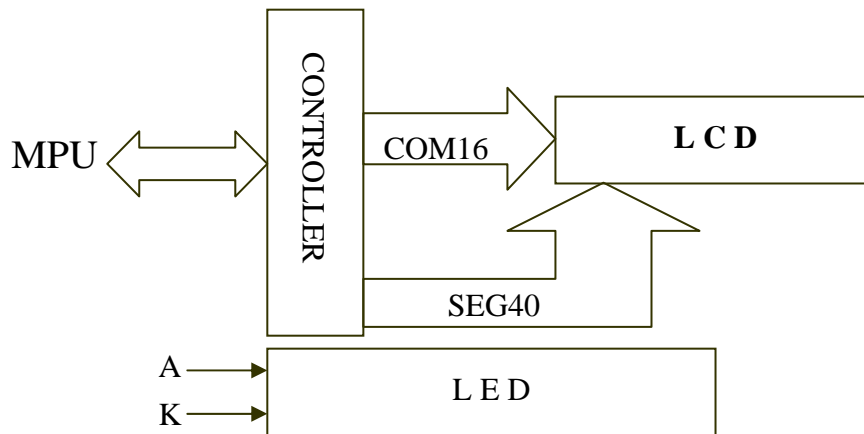

4 Timing Characteristics

(1) Write mode timing diagram (Writing Data from MPU to SPLC780C)

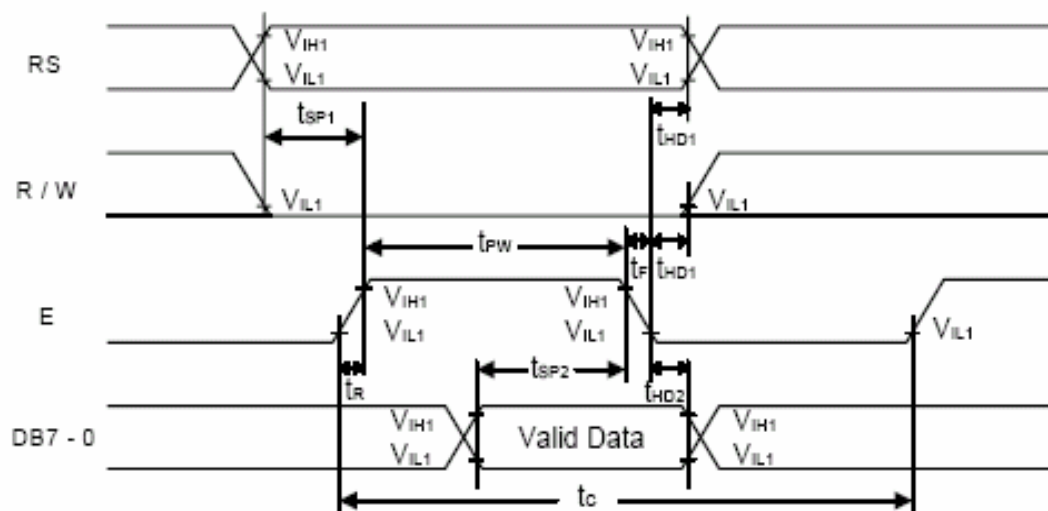

CHINA DISPLAY TECHNOLOGY CO., LTD.

(2) Read mode timing diagram (Read Data from SPLC780C to MPU)

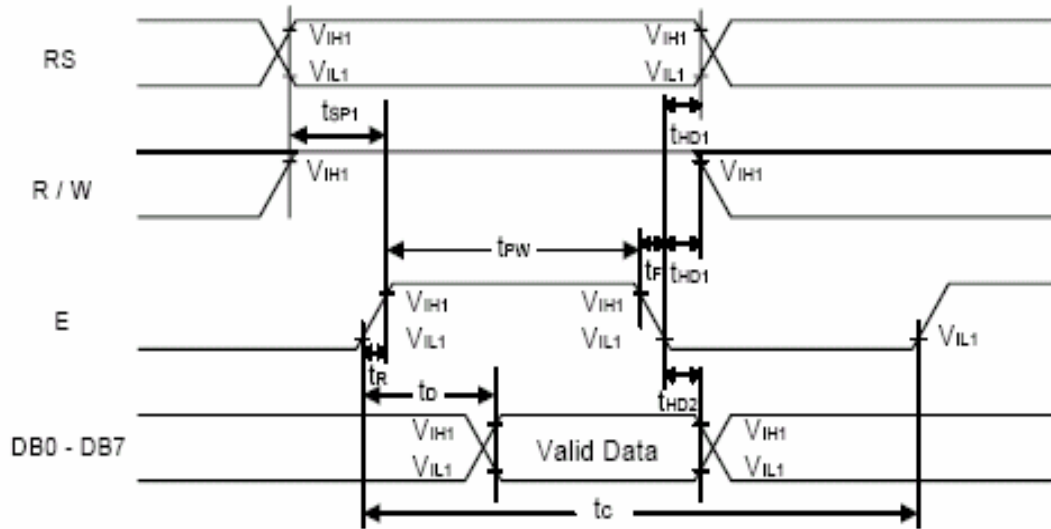

5 CODE DESCRIPTION

Instruction	Instruction Code										Description	Execution time (fosc=270KHz)	
	RS	RW	DB7	DB6	DB5	DB4	DB3	DB2	DB1	DB0			
Clear Display	0	0	0	0	0	0	0	0	0	1	Write "20H" to DDRAM and set DDRAM address to "00H" from AC	1.52ms	
Return Home	0	0	0	0	0	0	0	0	0	1	- Set DDRAM address to "00H" from AC and return cursor to its original position if shifted. The contents of DDRAM are not changed.	1.52ms	
Entry Mode Set	0	0	0	0	0	0	0	0	1	I/D	S	Assign cursor moving direction and enable the shift of entire display	38μs
Display ON/OFF Control	0	0	0	0	0	0	0	1	D	C	B	Set display(D), cursor(C), and blinking of cursor(B) on/off control bit.	38μs
Cursor or Display Shift	0	0	0	0	0	1	S/C	R/L	-	-	-	Set cursor moving and display shift control bit, and the direction, without changing of DDRAM data.	38μs
Function Set	0	0	0	0	1	DL	N	F	-	-	-	Set interface data length (DL: 8-bit/4-bit), numbers of display line (N: 2-line/1-line) and, display font type (F:5x10 dots/5x8 dots)	38μs
Set CGRAM Address	0	0	0	1	AC5	AC4	AC3	AC2	AC1	AC0	-	Set CGRAM address in address counter.	38μs
Set DDRAM Address	0	0	1	AC6	AC5	AC4	AC3	AC2	AC1	AC0	-	Set DDRAM address in counter	38μs
Read Busy Flag and Address Counter	0	1	BF	AC6	AC5	AC4	AC3	AC2	AC1	AC0	-	Whether during internal operation or not can be known by reading BF. The contents of address counter can also be read.	
Write Data to RAM	1	0	D7	D6	D5	D4	D3	D2	D1	D0	-	Write data into internal RAM (DDRAM/CGRAM).	38μs
Read Data from RAM	1	1	D7	D6	D5	D4	D3	D2	D1	D0	-	Read data from internal RAM (DDRAM/CGRAM).	38μs

Note: "-": don't care

6 Electro-Optical Characteristics

6.1 Electro-Optical Characteristics Test Method

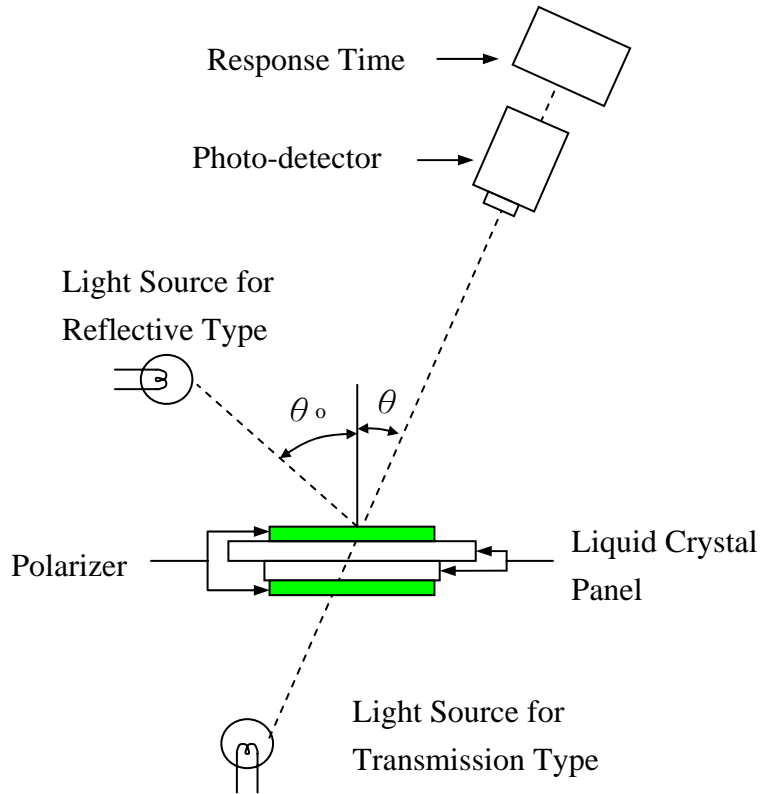

6.2 Definition of Operating Voltage, V_{op}

$$V_{op} = (V_{10,ON} + V_{90,OFF})/2$$

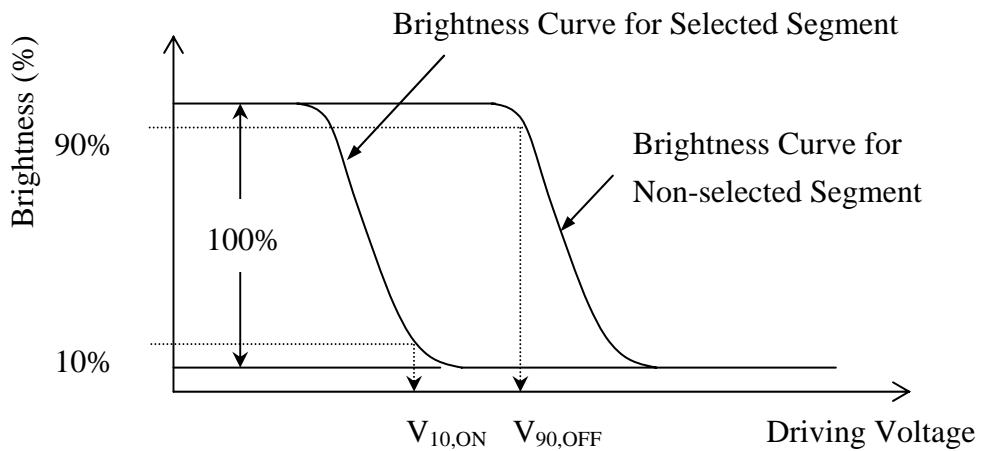

CHINA DISPLAY TECHNOLOGY CO., LTD.

6.3 Definition of Optical Response Time

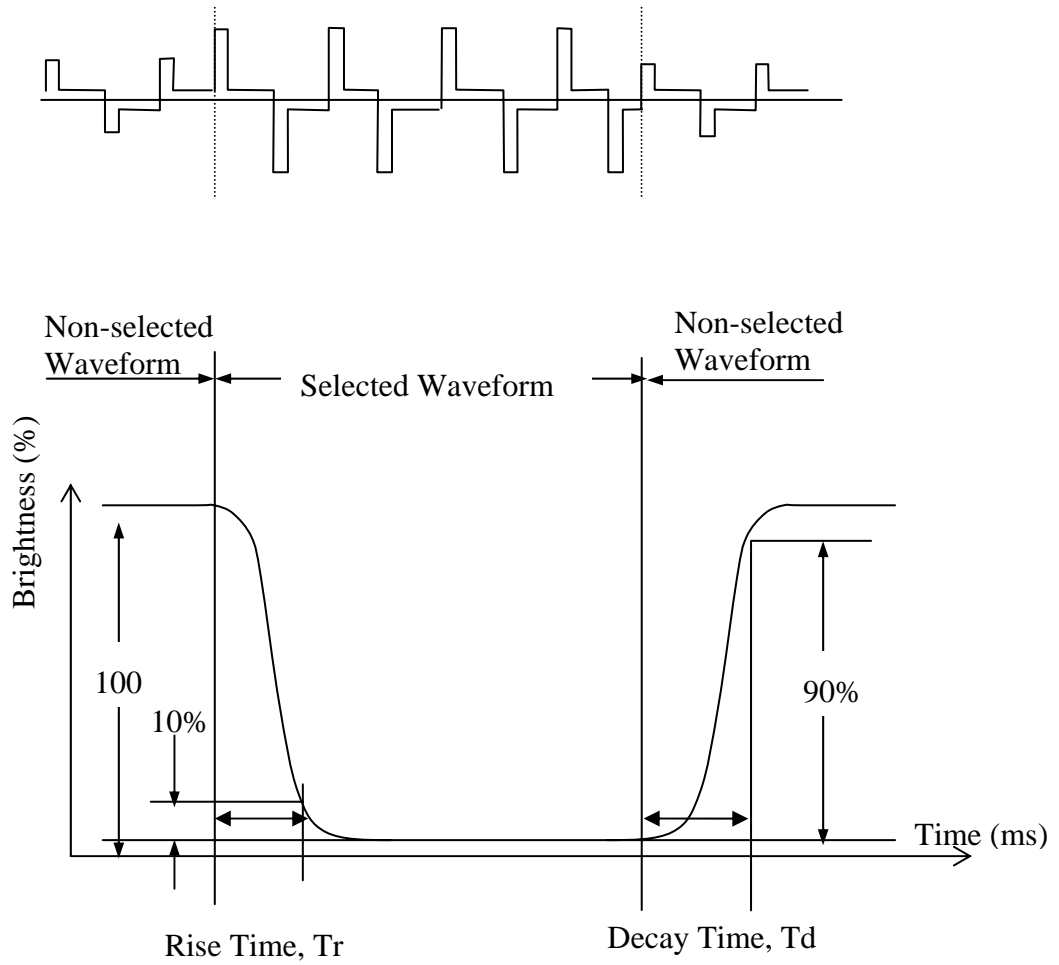

6.4 Definition of Viewing Angle θ and φ

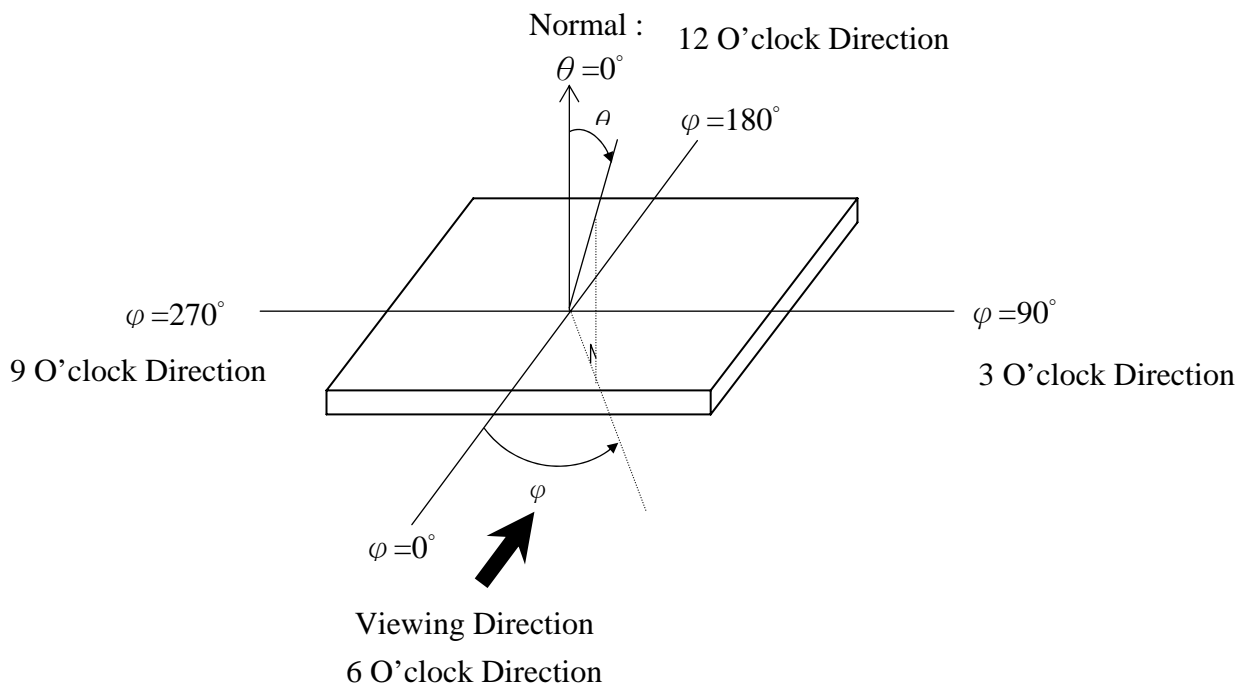

CHINA DISPLAY TECHNOLOGY CO., LTD.

6.5 Definition of Contrast ratio, CR

$$CR = \frac{\text{Brightness of Non-selected Segment (B2)}}{\text{Brightness of Selected Segment (B1)}}$$

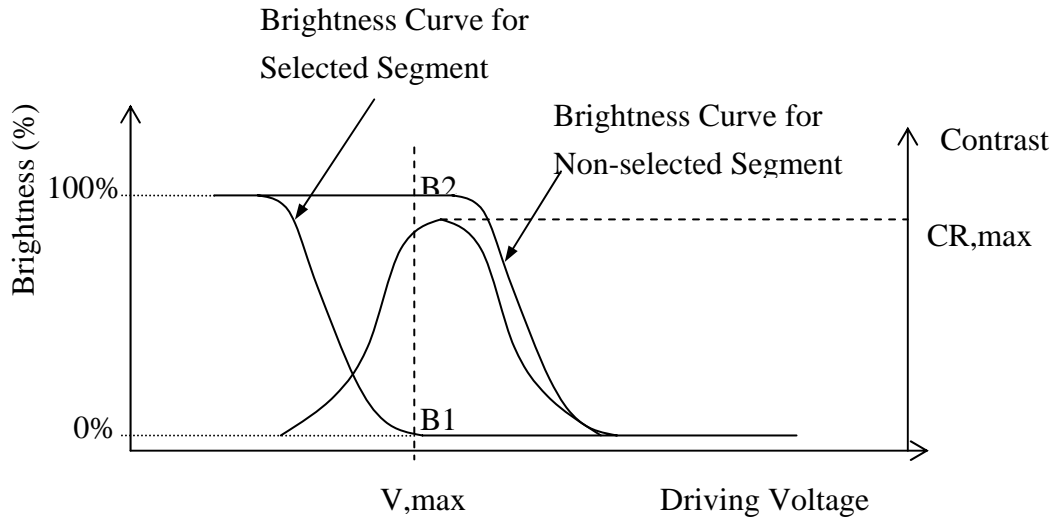

6.6 Reliability Test

6.6.1 Content of Reliability Test

No.	Test Item	Content of Test	Condition
Environmental Test			
1	High Temperature Storage	Endurance test applying the high temperature for a long time	60°C 120H
2	Low Temperature Storage	Endurance test applying the low temperature for a long time	-10°C 120H
3	High Temperature/Humidity Storage	Endurance test applying the high temperature and high humidity for a long time	40°C & 90% RH 100H
4	Heat Shock	<p style="text-align: center;">Endurance test applying The low and high temperature cycles</p> <p style="text-align: center;"> ← ↔ → </p> <p style="text-align: center;"> -10°C (1H) 60°C (1H) </p> <p style="text-align: center;">1 Cycle</p>	-10 / 60°C 5 cycle

6.6.2 Failure Judgement Criterion

After the above-mentioned test

There should not exist conspicuous failure of display quality and appearance.

No degradation of the display readability.

There should not have any abnormality of function.

7 Precautions for Using LCD Module

7.1 Handling Precautions

- (1) The display panel is made of glass. Do not subject it to a mechanical shock or impact by dropping it.
- (2) If the display panel is damaged and the liquid crystal substance leaks out, be sure not to get any in your mouth. If the substance contacts your skin or clothes, wash it off using soap and water.
- (3) Do not apply excessive force to the display surface or the adjoining areas since this may cause the color tone to vary.
- (4) The polarizer covering the display surface of the LCD module is soft and easily scratched. Handle this polarizer carefully.
- (5) If the display surface becomes contaminated, breathe on the surface and gently wipe it with a soft dry cloth. If it is heavily contaminated, moisten a cloth with one of the following solvents:
 - Isopropyl alcohol
 - Ethyl alcohol
- (6) Solvents other than those above mentioned may damage the polarizer.
Especially, do not use the following:
 - Water
 - Ketone
 - Aromatic solvents
- (7) Extra care to minimize corrosion of the electrode. Water droplets, moisture condensation or a current flow in a high-humidity environment accelerates corrosion of the electrode.
- (8) Install the LCD Module by using the mounting holes. When mounting the LCD Module, make sure it is free of twisting, warping and distortion. In particular, do not forcibly pull or bend the I/O cable or the backlight cable.
- (9) Do not attempt to disassemble or process the LCD Module.
- (10) NC terminal should be open. Do not connect anything.
- (11) If the logic circuit power is off, do not apply the input signals.
- (12) To prevent destruction of the elements by static electricity, be careful to maintain an optimum work environment.
 - Be sure to ground the body when handling the LCD Module.
 - Tools required for assembling, such as soldering irons, must be properly grounded.
 - To reduce the amount of static electricity generated, do not conduct assembling and other work under dry conditions.
 - The LCD Module is coated with a film to protect the display surface. Exercise care when peeling off this protective film since static electricity may be generated.

7.2 Others

- (1) Liquid crystals solidify under low temperature (below the storage temperature range) leading to defective orientation or the generation of air bubbles (black or white). Air bubbles may also be generated if the module is subject to a low temperature.
- (2) If the LCD Module have been operating for a long time showing the same display patterns the display patterns may remain on the screen as ghost images and a slight contrast irregularity may also appear. A normal operating status can be recovered by suspending use for some time. It should be noted that this phenomenon does not adversely affect performance reliability.
- (3) To minimize the performance degradation of the LCD Module resulting from destruction caused by static electricity etc. exercise care to avoid holding the following sections when handling the modules.
 - Exposed area of the printed circuit board.
 - Terminal electrode sections.
 -

8 Using LCD Modules

8.1 Liquid Crystal Display Modules

LCD is composed of glass and polarizer. Pay attention to the following items when handling.

- (1) Please keep the temperature within specified range for use and storage. Polarization degradation, bubble generation or polarizer peel-off may occur with high temperature and high humidity.
- (2) Do not touch, push or rub the exposed polarizers with anything harder than a HB pencil lead (glass, tweezers, etc).
- (3) N-hexane is recommended for cleaning the adhesives used to attach front/rear polarizers and reflectors made of organic substances, which will be damaged by chemicals such as acetone, toluene, toluene, ethanol and isopropyl alcohol.
- (4) When the display surface becomes dusty, wipe gently with absorbent cotton or other soft material like chamois soaked in petroleum ether. Do not scrub hard to avoid damaging the display surface.
- (5) Wipe off saliva or water drops immediately, contact with water over a long period of time may cause deformation or color fading.
- (6) Avoid contacting oil and fats.
- (7) Condensation on the surface and contact with terminals due to cold will damage, stain or polarizers. After products are tested at low temperature they must be warmed up in a container before coming is contacting with room temperature air.
- (8) Do not put or attach anything on the display area to avoid leaving marks on.
- (9) Do not touch the display with bare hands. This will stain the display area and degrade insulation between terminals (some cosmetics are determinate to the polarizers).

CHINA DISPLAY TECHNOLOGY CO., LTD.

- (10) As glass is fragile, it tends to become or chipped during handling especially on the edges.
Please avoid dropping or jarring.

8.2 Installing LCD Module

Attend to the following items when installing the LCM.

- (1) Cover the surface with a transparent protective plate to protect the polarizer and LC cell.
- (2) When assembling the LCM into other equipment, the spacer to the bit between the LCM and the fitting plate should have enough height to avoid causing stress to the module surface, refer to the individual specifications for measurements. The measurement tolerance should be $\pm 0.1\text{mm}$.

8.3 Electro-Static Discharge Control

Since this module uses a CMOS LSI, the same careful attention should be paid for electrostatic discharge as for an ordinary CMOS IC.

- (1) Make certain that you are grounded when handling LCM.
- (2) Before removing LCM from its packing case or incorporating it into a set, be sure the module and your body have the same electric potential.
- (3) When soldering the terminal of LCM, make certain the AC power source for the soldering iron does not leak.
- (4) When using an electric screwdriver to attach LCM, the screwdriver should be of ground potentiality to minimize as much as possible any transmission of electromagnetic waves produced sparks coming from the commutator of the motor.
- (5) As far as possible, make the electric potential of your work clothes and that of the workbenches to the ground potential.
- (6) To reduce the generation of static electricity, be careful that the air in the work is not too dried. A relative humidity of 50%-60% is recommended.

8.4 Precaution For Soldering To The LCM

- (1) Observe the following when soldering lead wire, connector cable and etc. to the LCM.

-Soldering iron temperature: $280 \pm 10^\circ\text{C}$.

-Soldering time: 3-4 sec.

-Solder: eutectic solder.

If soldering flux is used, be sure to remove any remaining flux after finishing to soldering operation. (This does not apply in the case of a non-halogen type of flux.) It is recommended that you protect the LCD surface with a cover during soldering to prevent any damage due to flux spatters.

- (2) When soldering the electroluminescent panel and PC board, the panel and board should not be

CHINA DISPLAY TECHNOLOGY CO., LTD.

detached more than three times. This maximum number is determined by the temperature and time conditions mentioned above, though there may be some variance depending on the temperature of the soldering iron.

- (3) When removing the electroluminescent panel from the PC board, be sure the solder has completely melted, otherwise the soldered pad on the PC board could be damaged.

8.5 Precaution For Operation

Viewing angle varies with the change of liquid crystal driving voltage (V_o). Adjust V_o to show the best contrast.

- (1) Driving the LCD in the voltage above the limit will shorten its lifetime.
- (2) Response time is greatly delayed at temperature below the operating temperature range. However, this does not mean the LCD will be out of the order. It will recover when it returns to the specified temperature range.
- (3) If the display area is pushed hard during operation, the display will become abnormal. However, it will return to normal if it is turned off and then on.
- (5) Condensation on terminals can cause an electrochemical reaction disrupting the terminal circuit. Therefore, it must be used under the relative condition of 40°C, 50% RH.
- (6) When turning the power on, input each signal after the positive/negative voltage becomes stable.

8.6 Storage

When storing LCDS as spares for some years, the following precaution are necessary.

- (1) Store them in a sealed polyethylene bag. If properly sealed, there is no need for desiccant.
- (2) Store them in a dark place. Do not expose to sunlight or fluorescent light, keep the temperature between 0°C and 35°C.
- (3) The polarizer surface should not come in contact with any other objects. (We advise you to store them in the container in which they were shipped.)
- (4) Environmental conditions:
 - Do not leave them for more than 168hrs. at 60 °C.
 - Should not be left for more than 48hrs. at -20 °C.

8.7 Safety

- (1) It is recommended to crush damaged or unnecessary LCDs into pieces and wash them off with solvents such as acetone and ethanol, which should later be burned.
- (2) If any liquid leaks out of a damaged glass cell and comes in contact with the hands, wash off thoroughly with soap and water.

CHINA DISPLAY TECHNOLOGY CO., LTD.

8.8 Limited Warranty

Unless agreed between China Display Technology and customer, China Display Technology will replace or repair any of its LCD and modules which are found to be functionally defective when inspected in accordance with China Display Technology LCD acceptance standards (copies available upon request) for a period of one year from date of shipments. Cosmetic/visual defects must be returned to China Display Technology within 90 days of shipment. Confirmation of such date shall be based on freight documents. The warranty liability of China Display Technology is limited to repair and/or replacement on the terms set forth above. China Display Technology will not be responsible for any subsequent or consequential events.