

Universal Motor - UM Series

Voltage : 100 - 240V AC (50/60 Hz)
 Rated Speed : 10000 - 20000 rpm
 Insulation Class : A, E, B, F, H
 Typical Applications : Electric Knife, Mini Chopper, Slicer, Blender,
 Juice Extractor, Hair Dryer, Bread Maker, Food Processor,
 Paper Shredder, Soy Bean Milk Maker, Air/Water Pump

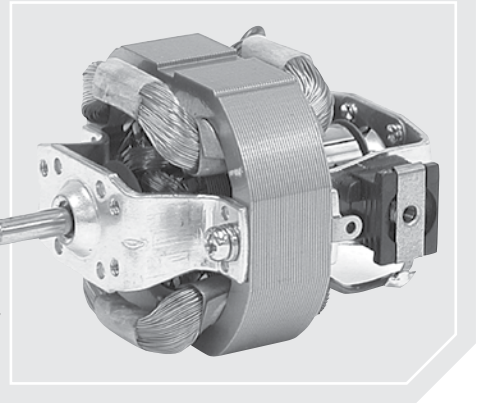

Performance Curve

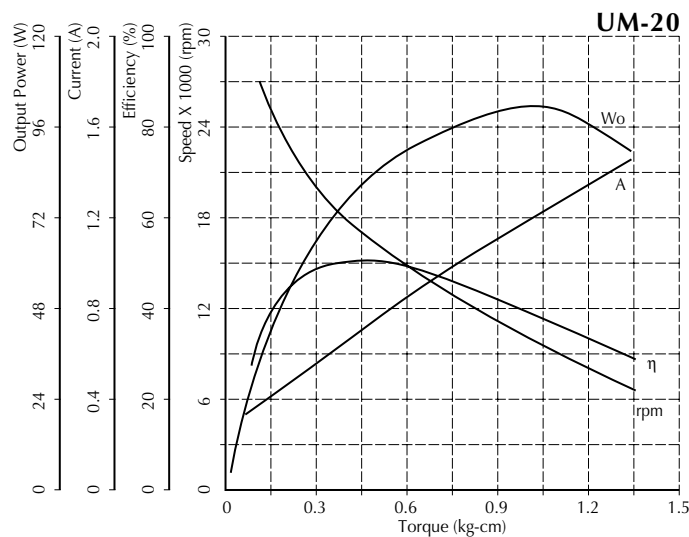

Dimension (mm)

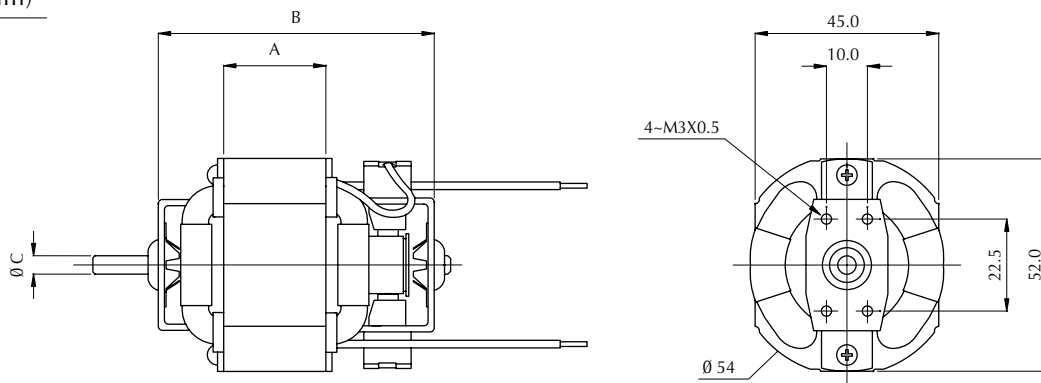

Performance (testing under room temperature)

Model	Dim A	Dim B	Dim C	Rated Torque/ kg-cm	Rated Input Power/ W
UM-10	10	52.5	4.5 / 6.35 / 8.0	0.20 - 0.27	30 - 90
UM-12	12	54.5	4.5 / 6.35 / 8.0	0.25 - 0.32	65 - 90
UM-15	15	57.5	4.5 / 6.35 / 8.0	0.25 - 0.32	65 - 90
UM-18	18	60.5	4.5 / 6.35 / 8.0	0.31 - 0.39	85 - 120
UM-20	20	62.5	4.5 / 6.35 / 8.0	0.35 - 0.44	110 - 160
UM-25	25	67.5	4.5 / 6.35 / 8.0	0.43 - 0.53	150 - 200
UM-30	30	72.5	4.5 / 6.35 / 8.0	0.52 - 0.64	190 - 240
UM-35	35	77.5	4.5 / 6.35 / 8.0	0.61 - 0.74	230 - 280
UM-40	40	82.5	4.5 / 6.35 / 8.0	0.70 - 0.85	270 - 320

The information above is for reference only, detailed specification is subject to final confirmation

Email: sales@cclmotors.com Web site: <http://www.cclmotors.com>

4/F, No. 6, On Lok Mun Street, On Lok Tsuen, Fanling, Hong Kong.

Tel: (852) 3125 0000

Fax: (852) 3125 0125