

NJ120

GENERAL DATA

Dielectric Strength		500V
Temperature Range	Intermittent	-20° F~-150° F (-28.9°C~65.6°C)
	Continuous	-20° F~-120° F (-28.9°C~48.9°C)
Mechanical Life (no load)		1×10 ⁵
Mounting Position		Recommended mounting is coil terminals up or horizontal
Duty Cycle		Continuous; Intermittent 30s "on" maximum and minimum 6 minutes "off"
Hardware Torque Specification	Contact Terminal	44-55 inch-lbs
	Coil Terminal	12-18 inch
Mass		170.5g

Features

- Water resistant.
- Capable of handling low and high current requirements.
- Versatile mounting and termination.

Ordering Information

NJ120 **A** **1** **DC6V** **1** **1** **1**
 1 2 3 4 5 6 7

- | | |
|--------------------------------------------------------------------------------------------------------------------------------------------------------------------------------------------------------------------------------------------------------------------------------------------------------------------------------------------------------------------------------------------------------------------------------------|-----------------------------------------------------------------------------------------------------------------------------------------------------------------------------------------------------------------------------------------------------------------------------------------------------------------------------------------------------------------------------------------------------------------------------------------------------------------------------------------------------------------------------------------------------------------------------------------|
| 1 Part number: NJ120
2 Contact arrangement: A:1A(SPNO);
3 Coil termination(15in-1b torque spec.):
1: Isolated w/#10-32 terminal(0.22 min. Length);
2: Grounded w/#10-32 terminal(0.220 min. Length);
3: Isolated w/1/4" Q.C terminal
4:Grounded w/1/4" Q.C terminal;
6:Grounded w/#8-32 tapered terminal
7:Grounded w/#10-32 terminal(0.451 min. length)
8: Grounded w/#10-32 terminal(0.451 min. Length) | 4 Coil Voltage:6,12,14,15,24,36,48
5 Contact Material and termination(55 in-lb torque spec.):
1:AgCdO w/5/16" -24 terminal (0.388min. Length)
3:Cu w/5/16" -24 terminal (0.388min. Length)
4:Cu w/1/4" -20 terminal
5:AgCdO w/5/16" -24 terminal (0.495min. Length)
6 Mounting Bracket: 1:Standard ;2: "L" shaped bracket
7 Factory Assigned Specials(where undefined,contact factory):
1:without hardware
2:Extra hardware loosely mounted to solenoid
5: Mounting bracket zincplated and dichromate dip
8:No hardware,mounting bracket as -5 option! |
|--------------------------------------------------------------------------------------------------------------------------------------------------------------------------------------------------------------------------------------------------------------------------------------------------------------------------------------------------------------------------------------------------------------------------------------|-----------------------------------------------------------------------------------------------------------------------------------------------------------------------------------------------------------------------------------------------------------------------------------------------------------------------------------------------------------------------------------------------------------------------------------------------------------------------------------------------------------------------------------------------------------------------------------------|

Contact Data

- Contact Arrangement: 1A (SPNO)
- Contact Material: silver alloy, Cu
- Termination: 5/16" -24 UNF-2A thread or 1/4" -20 UNC-2A thread
- Contact rating

Volts DC(V)	Conti.(A)	Inrush(A)	Elec. Life	Contact Material
12	80	400	1×10 ⁴	Copper
12	100	400	5×10 ⁴	silver alloy
36	100	400	2.5×10 ⁴	silver alloy

Coil parameter

- Termination: #8-32 UNC-2A, #10-32 UNF-2A thread or 1/4" quick-connect.
- Connections:
 - Coil isolated(two terminals);
 - One coil lead grounded to bracket(one terminal).
- Coil data:

Coil voltage (VDC)		Coil Resistance (Ω)		Operate Voltage (VDC)		Coil power (W)	
Rated	Max.	Intermittent	Continuous	Intermittent (67% of rated voltage)	Continuous (75% of rated voltage)	Intermittent	Continuous
6	6.6	*	4.0	4.02	4.5	14.4	8.1
12	13.2	6.0	16.0	8.04	9		
14	15.4	*	26.0	9.38	10.5		
15	16.5	9.4	23.0	10.05	11.25		
24	26.4	24.0	64.0	16.08	18		
36	39.6	54.0	160.0	24.12	27		
48	52.8	*	256.0	32.16	36		

*Special coils available upon request.

Dimensions

Inch

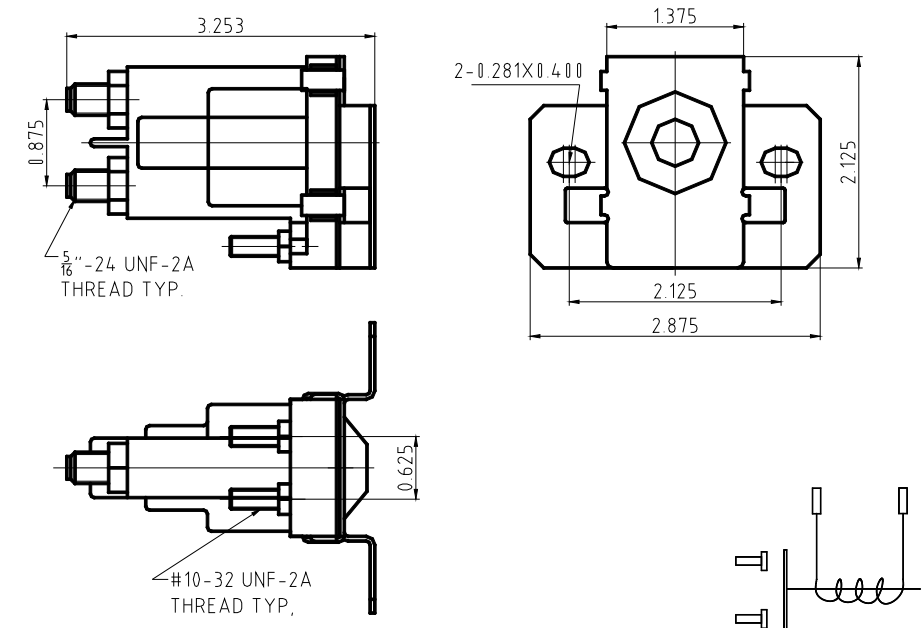

Dimensions and Mounting

Wiring diagram

APPLICATION NOTES:

- Not all number combinations are available. Please contact your Sales Representative for available part numbers.
- Solenoids applied in battery charging circuits should be protected from higher than rated voltage during charging. The service life may be affected by this condition and the solenoid may or may not operate the circuit as intended.
- Circuits should be designed to provide safe operation should the solenoid fail in either the open or closed position.
- A back-up wrench must be used to hold the bottom nut stationary during installation.