

User Manual



Code Scanner

Table of Contents

1. Getting Started	-----	
2		
2. Safety Warning	-----	
3		
3. About OBD-II	-----	4
3.1 OBD-II Terminology		
3.2 Diagnostic Trouble Code		
4. How to Use the Code Scanner	-----	12
4.1 Battery Installation		
4.2 Code Scanner Button Function		
4.3 LCD Screen Layout		
4.4 Read Diagnostic Trouble Code		
4.5 Clear Diagnostic Trouble Code		
4.6 Other Features		
5. One Year Warranty	-----	
18		
6. Diagnostic Trouble Code Definitions	-----	
19		

Table 1: Generic DTC Definitions

Table 2: Manufacturer DTC Definitions -- Ford

Table 3: Manufacturer DTC Definitions -- General Motors

Table 4: Manufacturer DTC Definitions -- Chrysler

Table 5: Manufacturer DTC Definitions -- Honda

Table 6: Manufacturer DTC Definitions -- Toyota

Table 7: Manufacturer DTC Definitions -- Nissan

Table 8: Manufacturer DTC Definitions -- Mazda

Table 9: Manufacturer DTC Definitions -- Isuzu

Table 10: Manufacturer DTC Definitions -- Volkswagen

Table 11: Manufacturer DTC Definitions -- Volvo

Table 12: Manufacturer DTC Definitions -- KIA

1. Getting Started

1. Stop the car and apply the parking brake. Turn the ignition key to the OFF position.
2. Connect the Code Scanner to vehicle's 16-pin Data Link Connector (DLC).
3. Turn the ignition key to the ON position.
4. Turn on the Code Scanner.
5. The Code Scanner will retrieve all vehicle's Diagnostic Trouble Codes (DTCs) and display them on the LCD screen.
6. Identify the DTCs with DTC definition table.



2. Safety Warnings

1. Do all testing only in a well-ventilated area.
2. Do not smoke. Keep sparks, open flames away from fuel system and the battery.
3. Always wear safety eye protection.
4. Don't contact with hot engine parts.
5. Keep people, tools and test equipment away from moving parts.
6. Turn the ignition OFF before connecting or disconnecting the scanner
7. Do not wear watches, rings and loose clothing when working on the engine.
8. Before performing any troubleshooting, place the transmission in Neutral (manual transmission) or Park (automatic transmission). Apply the parking brake and block the drive wheels.
9. Always follow vehicle manufacture's warning and service procedures.

3. About OBD-II

OBD-II stands for second-generation onboard diagnostics. OBD-II is a system developed by Society of Automotive Engineers (SAE) to reduce engine emission and standardize automotive electronic diagnosis. Beginning with the 1996 model year, all domestic and import cars and light trucks sold in USA and Canada must be fully OBD-II compliant.

3.1 OBD-II Terminology

To better understand OBD-II logic, you should know a few basic terms and their definitions.

Powertrain Control Module (PCM):

PCM is the on-board computer controlling the engine management and emissions systems. Some vehicles also have electronic transmission functions as part of the PCM responsibilities.

Malfunction Indicator Lamp (MIL):

Malfunction Indicator Lamp is also called Check Engine or Warning Light. The MIL illuminates when OBD-II detects a failure of the emission-related components and systems. The MIL may come on immediately with some faults, but may not come on with others until a failure has occurred on

two or three consecutive trips. The light will generally remain on until there are three consecutive trips without the fault reoccurring

Monitor:

Monitors are a set of diagnostic evaluations. OBD-II runs these diagnostic tests to monitor the performance of the vehicle's emissions-related components and systems. Most diagnostic monitors do not turn the MIL on when the vehicle fails a test for the first time. Instead a Pending Code is set along with the related freeze frame data. If the test fails on a second or even third consecutive trip, however, the MIL is illuminated and a DTC is stored.

As of this writing, there are only eleven Monitors in OBD-II system, and not all of these monitors apply to every vehicle.

Continuous Monitors: The Continuous Monitors continuously monitor their related components and systems when the engine is in operation. There are three Continuous Monitors. Following is a brief explanation of each Continuous Monitor

1. **Misfire Monitor:** Misfire Monitor is designed to continuously monitor engine misfire.

A misfire occurs while a lack of combustion or an instability of combustion. Misfire Monitor detects engine misfire by checking crankshaft speed fluctuations. Misfire Monitor is either a one-trip or a two-trip monitor.

2. **Fuel System Monitor:** Fuel System Monitor is designed to continuously monitor fuel meter system.

This monitor checks the fuel system to optimize engine combustion condition by using the feedback

from the oxygen and other sensors. Fuel System Monitor is either a one-trip or a two-trip monitor.

- 3. Comprehensive Component Monitor (CCM):** CCM is designed to continuously monitor all electronic components and systems. PCM checks all inputs and outputs to detect the malfunctions for lack of circuit continuity (open circuit, internal shorts, short to ground) and rationality (out of range value). CCM is either a one-trip or a two-trip monitor.

Non-Continuous Monitors: Non-Continuous Monitors monitor their related components and systems only under specific conditions. Usually, they run their diagnostic tests once per trip. There are eight Non-Continuous Monitors. Following is a brief explanation of each Non-Continuous Monitor.

- 1. Catalyst Monitor:** This monitor is designed to monitor the conversion efficiency of the catalytic converter. The catalytic convert installed downstream of the exhaust manifold is used to convert the exhaust pollutants (HC, CO and NO_x) into carbon dioxide (CO₂), water (H₂O) and nitrogen. PCM checks the catalytic converter by comparing the signal between the upstream and downstream O₂ sensors. Catalyst Monitor is a two-trip monitor.
- 2. Heated Catalyst Monitor:** This monitor is designed to monitor and optimize the performance of the heated catalytic converter. The heated catalytic converter is similar to the catalytic converter described above. The only

difference is that a heater element is added, so the heated catalytic converter can reach its operating temperature more quickly. Heated Catalyst Monitor is also a two-trip monitor.

- 3. Evaporative System (EVAP) Monitor:** This monitor is designed to monitor the evaporative emission control system.
The EVAP detects the level of hydrocarbon (HC) loss to prevent the HC vapors from evaporating into the atmosphere. OBD-II vehicle must be equipped with the EVAP system. EVAP Monitor is a two-trip monitor.
- 4. Secondary Air System Monitor:** This monitor is designed to monitor the secondary air injection system.
The secondary air system injects air into the exhaust manifold to reduce cold start emissions. The Secondary Air System Monitor is a two-trip monitor.
- 5. Air Conditioning (A/C) System Refrigerant Monitor:** This monitor is designed to monitor the leaks of refrigerant in air conditioning system.
- 6. Oxygen Sensor Monitor:** This monitor is designed to monitor the oxygen sensor.
The PCM checks the amplitude of the oxygen sensor signal to adjust the air/fuel mixture. Oxygen Sensor Monitor is a two-trip monitor.
- 7. Oxygen Sensor Heater Monitor:** This monitor is designed to monitor the oxygen sensor heater.

The PCM checks the performance of the oxygen sensor heater to ensure that it is heating the sensor during cold start conditions. Oxygen Sensor Heater Monitor is a two-trip monitor.

- 8. Exhaust Gas Recirculation (EGR) Monitor:** This monitor is designed to monitor the Exhaust Gas Recirculation (EGR) system.

The ERG system helps reduce the combustion chamber temperature, thereby reducing NOx emissions. Exhaust Gas Recirculation (EGR) Monitor is a two-trip monitor.

Enable Criteria:

Each Monitor has a certain number of conditions or driving procedures that need to be met before it is executed. The requirements and conditions vary for each Monitor. Some common Enable Criteria are: engine speed, engine temperature, vehicle speed, barometric pressure, ECT, MAF/MAP, IAT, TPP, canister purge, fuel trim, TCC enable and A/C on-signal.

Trip:

A Trip for a particular Monitor is a key-on, key-off drive cycle allowing the vehicle to satisfy the Enable Criteria to run and complete its diagnostic testing.

Monitor Complete/Monitor Not Complete:

Monitor Complete indicates the OBD-II has utilized the particular Monitor to run and complete the required diagnostic testing on the related system and section. That also means the Trip for that particular Monitor has run and completed. Monitor Not Complete means the OBD-II has not yet completed the required diagnostic testing for that particular Monitor.

OBD-II Drive Cycle:

The OBD-II Drive Cycle is a key-on, key-off cycle that must satisfy all the Enable Criteria for all the applicable Monitors on a particular vehicle to run and complete their diagnostic testing. The purpose of OBD-II Drive Cycle is to run and complete all of the on-board diagnostics

Warm-up Cycle:

A Warm-up Cycle is defined as vehicle operation where coolant temperature must reach at least 160° F (70° C) and rise at least 40° F (22° C).

3.2 Diagnostic Trouble Code (DTC)

An OBD-II equipped vehicle will turn on the MIL and log a Diagnostic Trouble Code (DTC) if OBD-II detects the degradation or failure of the emissions-related components and systems. The MIL may not come on when the vehicle fails a test for the first time. Instead a Pending Code is set along with the related freeze frame data. If the test fails on a second or even third consecutive trip, however, the MIL is illuminated and a DTC is stored.

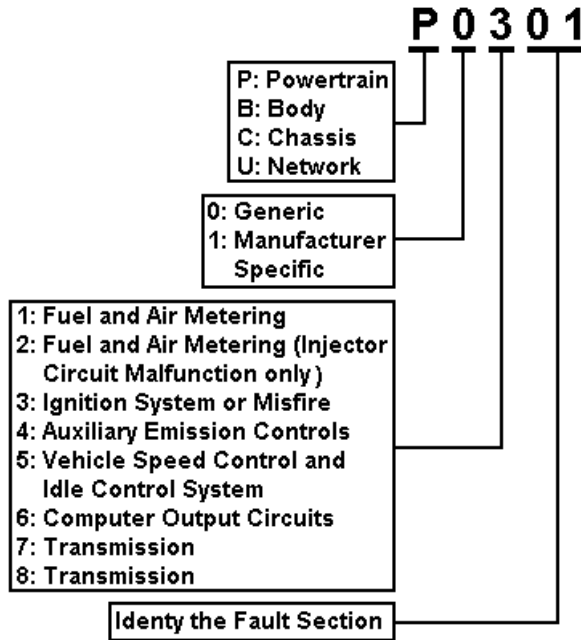

A typical DTC is shown above. It consists of five characters: four digits preceded by one letter. The first letter indicates the main system where the fault is located (Powertrain, Body, Chassis or Network). The second character is a number and it identifies whether the code is an SAE standard code (Generic) or manufacture specific code. The remaining three numbers provide information regarding the sub-system and section that are malfunctioning.

4. How to Use the Code Scanner

This OBD-II Code Scanner is designed to read and clear vehicle's DTCs and Pending DTCs, check vehicle's Monitor status Since it supports all major OBD2 protocols, ISO-1941-2, KWP2000, VPW and PWM, you will be able to use it on any 1996 or newer car.



4.1 Battery Installation

1. Remove the battery cover on the back of the Code Scanner.
2. Install the 9V battery inside the battery compartment.
3. Reinstall the battery cover.

4.2 Code Scanner Button Function

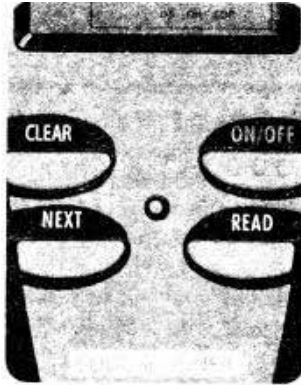

1. **ON** button: Turn on the Code Scanner.
2. **READ** button: Link to vehicle's PCM to retrieve any DTC and check Monitor status.
3. **NEXT** button: Show the next DTC if there is more than one DTCs.
4. **CLEAR** button: Link to the vehicle's PCM to clear DTCs and freeze frame data, reset Monitor status.

4.3 LCD Screen Layout

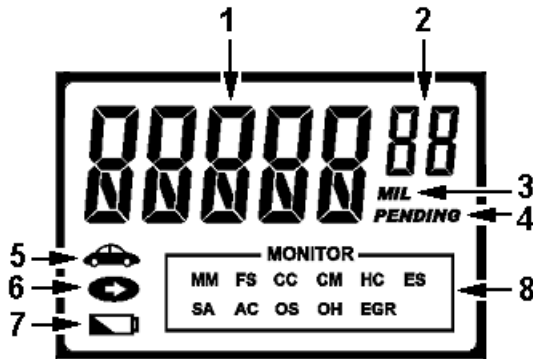

1. **DTC Area:** Display the 5-character Diagnostic Trouble Code.
2. **DTC Index:** Display the index number of DTCs
3. **MIL Icon:** Indicate the status of the MIL.
4. **PENDING Icon:** Indicate whether the DTC is a Pending Code or not.
5. **Car Icon:** Indicate whether or not the Code Scanner is properly connected with vehicle's DLC and powered by vehicle's battery.
6. **Link Icon:** Indicate whether the Code Scanner successfully communicates with the vehicle's PCM or not.
7. **Battery Icon:** Indicate whether the Code Scanner's internal battery is low or not.
8. **Monitor Status Area:** Indicate which Monitors are supported and the supported Monitors whether or not have run and completed. The eleven Monitor icons are listed below.
 - **MM** --- Misfire Monitor
 - **FS** --- Fuel System Monitor
 - **CC** --- Comprehensive Component Monitor
 - **CM** --- Catalyst Monitor
 - **HC** --- Heated Catalyst Monitor

- **ES** --- Evaporative System Monitor
- **SA** --- Secondary Air System Monitor
- **AC** --- Air Conditioning System
Refrigerant Monitor
- **OS** --- Oxygen Sensor Monitor
- **OH** --- Oxygen Sensor Heater Monitor
- **EGR** --- Exhaust Gas Recirculation Monitor

4.4 Read Diagnostic Trouble Code

1. Stop the car and apply the parking brake. Turn the ignition key to the **OFF** position.
2. Connect the OBD-II Code Scanner cable to vehicle's 16-pin Data Link Connector (DLC).
3. Turn the ignition key to the **ON** position. (Do not start the engine.)
4. Press the Code Scanner's **ON** button to turn on the Code Scanner.
 - The car icon will display at this time to indicate the Code Scanner is correctly connected with vehicle's DLC and powered by vehicle's battery.
5. Press the Code Scanner's **READ** button. The LCD screen will show **REAd** while the Scanner is retrieving the code. After retrieving, the Code Scanner will show the link icon, the DTCs and Monitor status.
 - If there are more than one DTC, press the **NEXT** button, the next DTC will be displayed. If there is no DTC in PCM, the LCD screen will show 0.

- The Monitor status area will show the vehicle's Monitor status. If a Monitor icon is solid, it means this Monitor is supported and complete. If a Monitor is flashing, that means this Monitor is supported but not complete. If a Monitor icon is not visible, it means this Monitor is not supported.
- If the Code Scanner is not properly connected with the vehicle's DLC and powered by vehicle's battery, the LCD screen will show **ERR** and the car icon will flash.
- If the Code Scanner fails to communicate with the vehicle, the LCD screen will show **ERR** and the link icon will flash.

4.5 Clear Diagnostic Trouble Code

1. Stop the car and apply the parking brake. Turn the ignition key to the **OFF** position
2. Connect the OBD-II Code Scanner cable to vehicle's 16-pin Data Link Connector (DLC).
3. Turn the ignition key to the **ON** position. (Do not start the engine.)
4. Press the Code Scanner's **ON** button to turn on the Code Scanner.
 - The car icon will display at this time to indicate the Code Scanner is correctly connected with vehicle's DLC and powered by vehicle's battery.
5. Press the Code Scanner's **CLEAR** button. The LCD screen will show **SURE**, hold the button for about 5 seconds, the Code Scanner will show **CLR** and begin

to erase PCM's DTCs and freeze frame data, reset Monitor status.

- If you don't want to erase the codes while the LCD screen indicates **SURE**, just release the **CLEAR** button. You couldn't stop the clearing procedure while LCD screen indicates **CLR**.
- The LCD screen will show **Ok** if the Code Scanner successfully finishes the clearing procedure, otherwise the LCD screen will show **ERR**.
- If the Code Scanner is not properly connected with the vehicle's DLC and powered by vehicle's battery, the LCD screen will show **ERR** and the car icon will flash.
- If the Code Scanner fails to communicate with the vehicle's PCM, the LCD screen will show **ERR** and the link icon will flash.

4.6 Other Features

- 9V internal battery for off-car display.
- Bright Backlight.
- Automatically turn off to save the internal battery energy.
- Battery low warning.
- Operating Temperature: -4°F (-20°C) \sim 122°F (50°C).

5. One Year Warranty

This OBD-II Code Scanner has one-year repair or exchange warranty for any defects in materials and workmanship.

This warranty does not apply to improperly installed, handled, abused, damaged in crash, nor to any unit that has been repaired by unauthorized agencies. Under no circumstances will the buyer be entitled to consequential or incidental damages. This limited warranty gives you specific legal rights; you may have other rights that vary from state to state.

This warranty applies only to the original purchaser and is not transferable.