

KM-37B528

Reduction Ratio							The length of gear box/L
10							17.8
20	30						21.5
50	60	70	90				24
150	180	210	270				26.5
360	450	540	630	810	280		29

OUTLINE

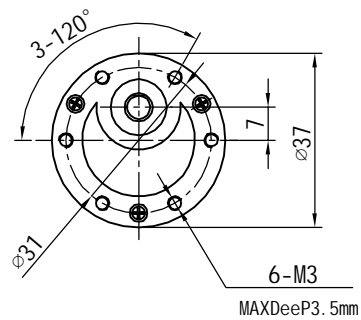
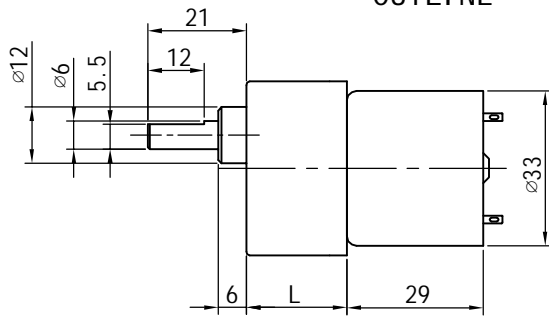

Motor Installation

MODEL	VOLTAGE		NO LOAD			ON LOAD				STALL	
	OPERING RANG	NOMINAL	CURRENT	SPEED	CURRENT	SPEED	TORQUE	I NPUT	TORQUE	CURRENT	
		V	A	r/min	A	r/min	g. cm	w	g. cm	A	
RF-528C-18250	9~14	12	0.06	7000	0.32	5600	45	2.42	230	1.7	
RF-528C-17300	20~28	24	0.03	6700	0.2	5300	50	2.84	310	1.0	

Geared Motor Installation

REDUCTION RATIO	1/10	1/30	1/50	1/90	1/150	1/210
NO LOAD SPEED(rpm)	700	233	140	77	46	33
NO LOAD CURRENT(mA)	65	65	65	70	70	70
RATCD TORQUE(kg. cm)	0.4	1.1	1.8	3.3	4.8	6.8
RATCD CURRENT(mA)	300	310	320	320	330	330
RATCD SPEED(rpm)	560	185	110	62	37	26