

ORDERING INFORMATION:

19 01132 - S 1 C - A
 (1) (2) (3) (4) (5) (6)

- (1) SERIES NUMBER:
19 : Adapter Series
- (2) SEQUENCE NO.
01132(EX.01001-01999):HDMI(FEMALE) TO HDMI(FEMALE) ADAPTER WITH EQ METAL SHELL EXTENDER
- (3) OUTER SHEEL APPEARANCE COLOR CODES:
S : Silver White
- (4) PLATING OF SHELL :
1 : SHELL PLATED GOLD
2 : SHELL PLATED NI
- (5) SUFFIX NO. :
C : TYPE III, WITHOUT DC POWER TYPE
- (6) CUSTOMER CODE. :
A : STANDARD TYPE

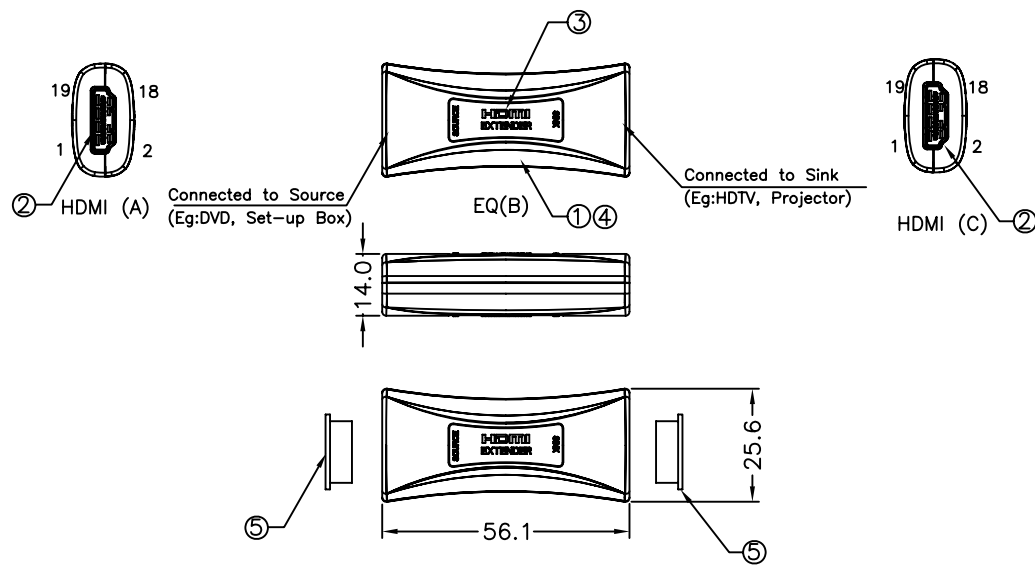

PIN ASSIGNMENT:

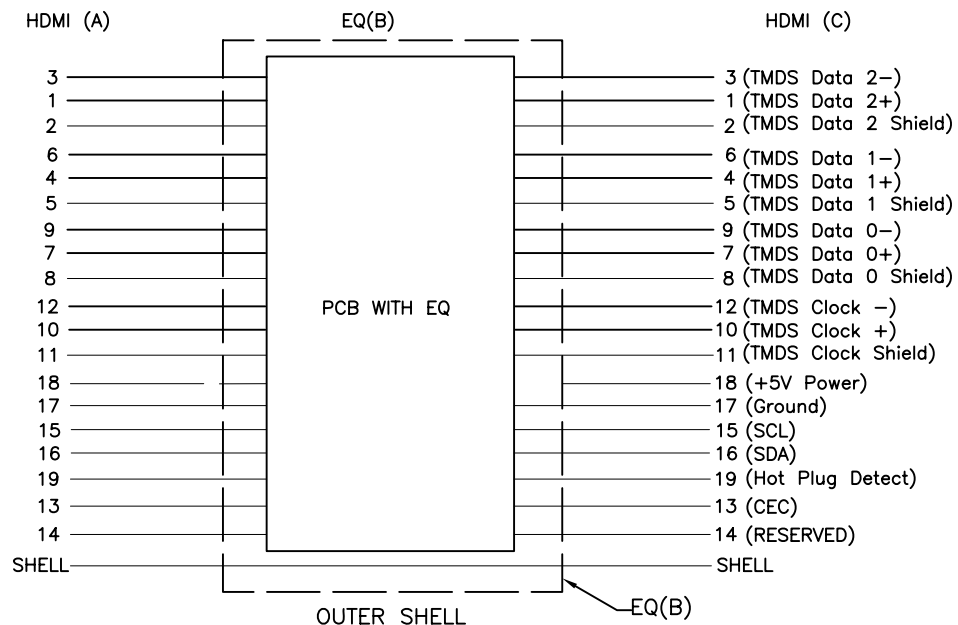

5	DUST COVER	PE, LOW DENSITY	2PCS
4	OUTER SHEEL	ZN-METAL PLATING PEARL-CR	2PCS
3	PANEL	AL-SHEET	2PCS
2	HDMI CONN	HDMI FEMALE SOLDER TYPE CONTACT PLATED 30u" Gold	2PCS
1	PCB	PCB WITH EQ, STRADDLE TYPE	1PC
NO.	PART NAME	SPEC DESCRIPTION	REMAKE

MATERIAL	TOLERANCE UNSPECIFIED ± ± ± ± ± ± ± ± ±		
		SCALE 1:1	UNIT mm
FINISH	DRAWN WRZ 06/11/06	NAME	
	DESIGNER WRZ 06/11/06	HDMI ADAPTOR WITH EQ	
	CHECKED	TYPE III	
	APPROVED	DRAWING NO. 1901132-S1C-A	SHEET 1/2
		REV 0.1	

